

The Ramsey SonaTech Sonic Level Indicator is easy to install and operate, requiring a minimal amount of operator input to set up and calibrate. This sonic level indicator uses highly accurate and sophisticated echo processing software to ensure that your process operates at its optimum level of performance. It will increase your profits and improve your bottom line.

## Ramsey SonaTech<sup>®</sup> Sonic Level Indicator

Accurate Sonic Level Detection of Bulk Solids and Liquids

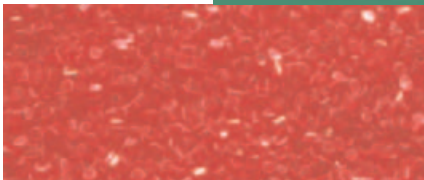

The Ramsey SonaTech Sonic Level Indicator from Thermo Electron Corporation is a continuous level measurement device that uses sound waves to accurately determine the level of solids or liquids in any given bin, tank, silo, or other container. Like all Ramsey sonic products, the Ramsey SonaTech Sonic Level Indicator uses frequencies lower than our competition's to penetrate dust, steam, vapors and other harsh environmental obstacles. This gives you precise and reliable readings in any bin condition.

Most of the sonic level measuring systems in use today do not perform optimally if their sound waves are subject

to interference from dust, air turbulence, steam or other environmental factors. That's because these are higher frequency systems that operate in the 20-50 kHz range, and higher frequency means diminished penetrating capability.

But Thermo's state-of-the-art Ramsey SonaTech systems provide more penetrating power, because they operate in the 5-30 kHz range. That means superior performance in dusty, turbulent or steamy atmospheres. The bottom line for you is more reliable inventory management over a wide range of applications—even the most difficult ones.

### System Operation

The Ramsey SonaTech Sonic Level Indicator is designed for basic level measurement applications. It's easy to install and operate, requiring a minimal amount of operator input to set up and calibrate. Though simple to operate, this level indicator uses sophisticated echo processing software to assure optimum performance and accuracy.

During operation, the Ramsey SonaTech Sonic Level Indicator transmits sound waves toward the stored material and receives the reflected echoes. Material level is then determined by calculating the elapsed time between sending the sound signal and receiving its echo. Our special software ignores false echoes that may be created by foreign objects and locks onto the real echo for an accurate reading. The correct signal is assigned parameters of possible change, thus producing a window that takes into consideration the actual material level and allowable changes. If the signal is lost for any reason, the electronics will automatically search within the programmed parameters to locate the "real" signal.

At the heart of the Ramsey SonaTech Sonic Level Indicator is one of several Ramsey transducers. They succeed where those from other manufacturers fail, because our models utilize an adaptive gain control that automatically compensates for changes in echo amplitude, and an automatic temperature compensator that adjusts to optimize accuracy. The transducers are sized according to each specific application.



### The Transducers

The Ramsey TRA-30 transducer is designed for short-range applications such as sumps, short feed bins, surge hoppers, and most liquid applications. Its 30 kHz frequency covers a maximum range of 5 m (15 ft) in solids and 10 m (30 ft) in liquids. Small and compact, it is easily mounted by its threaded barrel; a pipe clamp; or a DN100/PN10 (4 in, 150 lb ANSI) mounting flange.

The Ramsey TRA-60 is popular because of its versatility and its ability to perform well in a wide variety of applications. Because of its 20 kHz frequency, it also can do longer-range simple applications up to 10 m (30 ft) in solids and 18 m (60 ft) in liquids. Coal bunkers, cement silos and grain storage terminals are ideal applications for this transducer.

The Ramsey TRA-75 is applied to mid-range solids applications that are considered very difficult, such as those with pneumatic fill or an extreme amount of dust. Its 15 kHz frequency excels in solids applications up to 14 m (45 ft) and in liquid ones up to 23 m (75 ft).

The Ramsey TRA-90 is designed for applications ranging up to 22 m (70 ft) in solids and 27 m (90 ft) in liquids.

The Ramsey TRA-200 is the ultimate sonic transducer. It is designed for difficult applications such as blending silos, or grain or coal storage bins that require measurement up to 30 m (100 ft) during filling. Its 5 kHz frequency easily handles 60 m (200 ft) in solids or 114 m (375 ft) in liquids.

### Quality Electronics Packages

Thermo's Ramsey electronics packages are designed to provide the correct amount of power and performance required for each specific level application. The following models illustrate this:

#### Ramsey SonaTech I

This model incorporates an integrated design, which combines the electronics and the transducer into a single unit. Its electronics are housed in a rugged polypropylene enclosure and come standard with two relays, or set points. It is ideal for volumetric batching and for some surge control applications.

#### Ramsey SonaTech I<sup>2</sup>

This model is essentially identical to the SonaTech I, but it comes with an additional 4-20mA output that is proportional to material level.

#### Ramsey SonaTech RS and RL

These models are remote versions of the Ramsey SonaTech Level Indicator. Their electronics can be mounted up to 90 m (300 ft) from the transducer and come standard with four relays and a 4-20mA output. The only difference between the RS and RL versions is the type of transducer they require.



## Features and Benefits

### Automatic Temperature Compensation

A small temperature sensor is built into every transducer to continuously monitor the air temperature in the vessel. The software automatically compensates for temperature changes to optimize accuracy.

### Easy to Install and Calibrate

Electronics can be pre-calibrated for repeat applications, which shortens start-up time.

### Simulation Program

This simulation program allows the set-up of interface with remote equipment (PLCs, etc.) without actually having to run the unit.

### Diagnostic Displays

These displays permit quick diagnosis and corrections of problems.

### Adaptive Gain

This compensates for changes in echo amplitude due to varying environmental conditions.

## Ramsey SonaTech R Remote Electronics

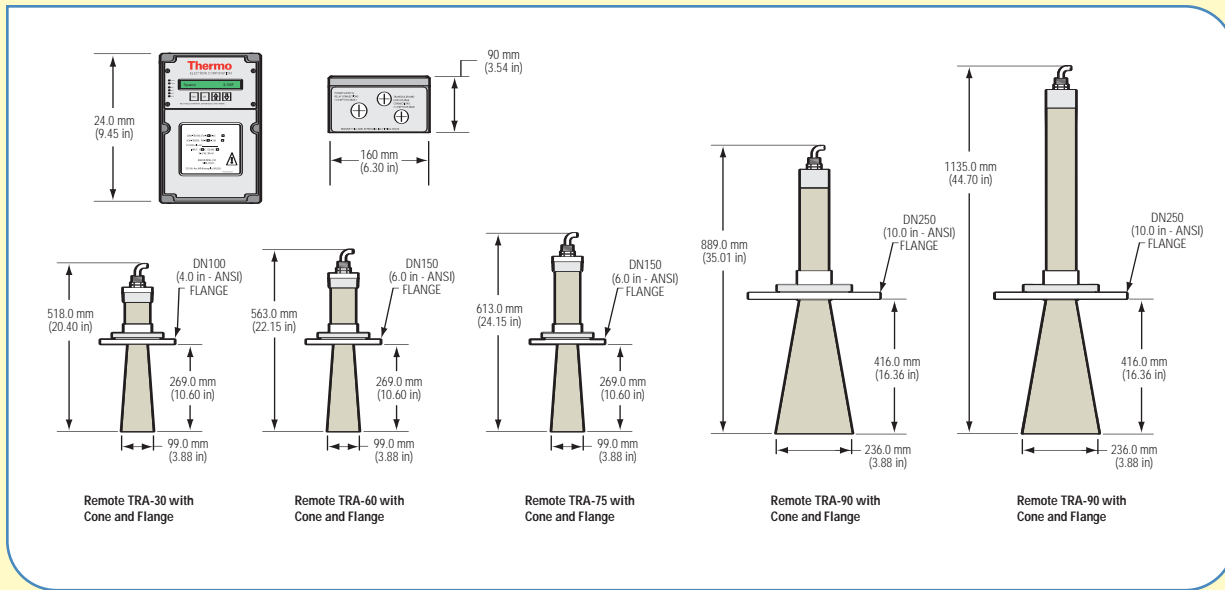

## Ramsey SonaTech Integral Electronics

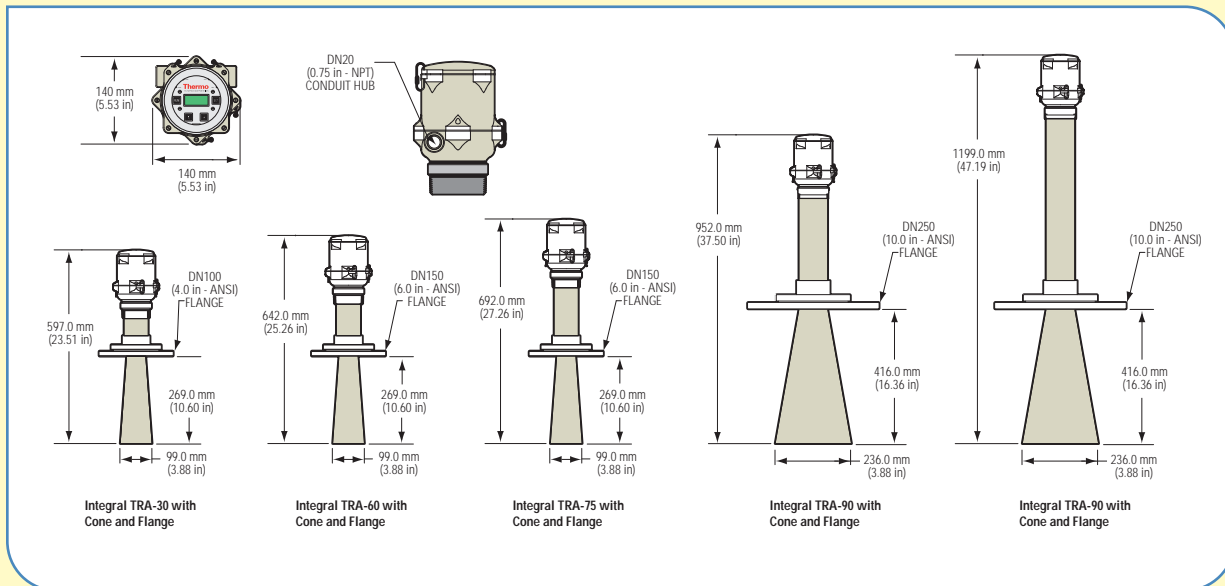

## Ramsey SonaTech® Sonic Level Indicator

Specification	
Supply Voltage	115 VAC standard; 230 VAC available
Enclosures	NEMA 4X; Polypropylene; Polycarbonate
Relays	
SonaTech I:	Two SPDT, 10 amps, 240 VAC resistive
SonaTech R:	Four SPDT, 10 amps, 240 VAC resistive
Temperature Compensation	Internal temperature sensor by transducer face
Current Output	Isolated 4-20 mA; 750 ohm maximum
Temperature Limits	Standard limits listed; High-temp versions available
Control Electronics	-40°C to +60°C (-40°F to +140°F)
Transducers	-40°C to +80°C (-40°F to +176°F)
Flange/Cone	+100°C (+212°F) maximum
Transducer Materials	Standard materials listed; Special materials available TRA-30: Polypropylene housing; Teflon face TRA-60: Polypropylene housing; Teflon face TRA-90: Polypropylene housing; Polyolfin/elastomer face TRA-200: Polypropylene housing; Polyolfin/elastomer face
Transducer/Amplifier Separation	Ramsey SonaTech R: 90 m (300 ft) maximum
Resolution	Capable of 0.1% of full range
Accuracy	Capable of 0.2% of full range

## Ramsey SonaTech® Transducer Selection

Transducer	Maximum Distance In Clean Air	Operating Frequency	Ramsey SonaTech I	Ramsey SonaTech I <sup>2</sup>	Ramsey SonaTech RS	Ramsey SonaTech RL
TRA-30	9 m (30 ft)	30 kHz	X	X	X	
TRA-60	18 m (60 ft)	20 kHz	X	X	X	
TRA-75	23 m (75 ft)	15 kHz	X	X	X	
TRA-90	27 m (90 ft)	10 kHz	X	X		X
TRA-200	60 m (200 ft)	5 kHz				X



© 2004 Thermo Electron Corporation. All rights reserved. Specifications, terms and pricing are subject to change. Not all products are available in all countries. Please consult your local sales representatives for details. Literature Code PI.8027.0704

### Process Instruments

Australia +61 (0) 8 8150 5300 +61 (0) 8 8234 5882 fax	Germany +49 (0) 208-824930 +49 (0) 208-852310 fax	Spain +34 91-657-3900 +34 91-661-5572 fax
Canada +1 (905) 888-8808 +1 (905) 888-8828 fax	Italy +39 02-959514-1 +39 02-953200-15 fax	United Kingdom +44 (0) 1788-820300 +44 (0) 1788-820301 fax
Chile +56 (0) 2-335-3388 +56 (0) 2-335-1590 fax	Netherlands +31 (0) 33-454-9000 +31 (0) 33-454-9009 fax	
China +86 (0) 516-7793650 +86 (0) 516-7793652 fax	South Africa +27 (0) 11-609-3101 +27 (0) 11-609-3110 fax	USA +1 (877) 290-7422 +1 (763) 783-2525 fax

[www.thermo.com](http://www.thermo.com)