

Ramsey 8120 Weighframe

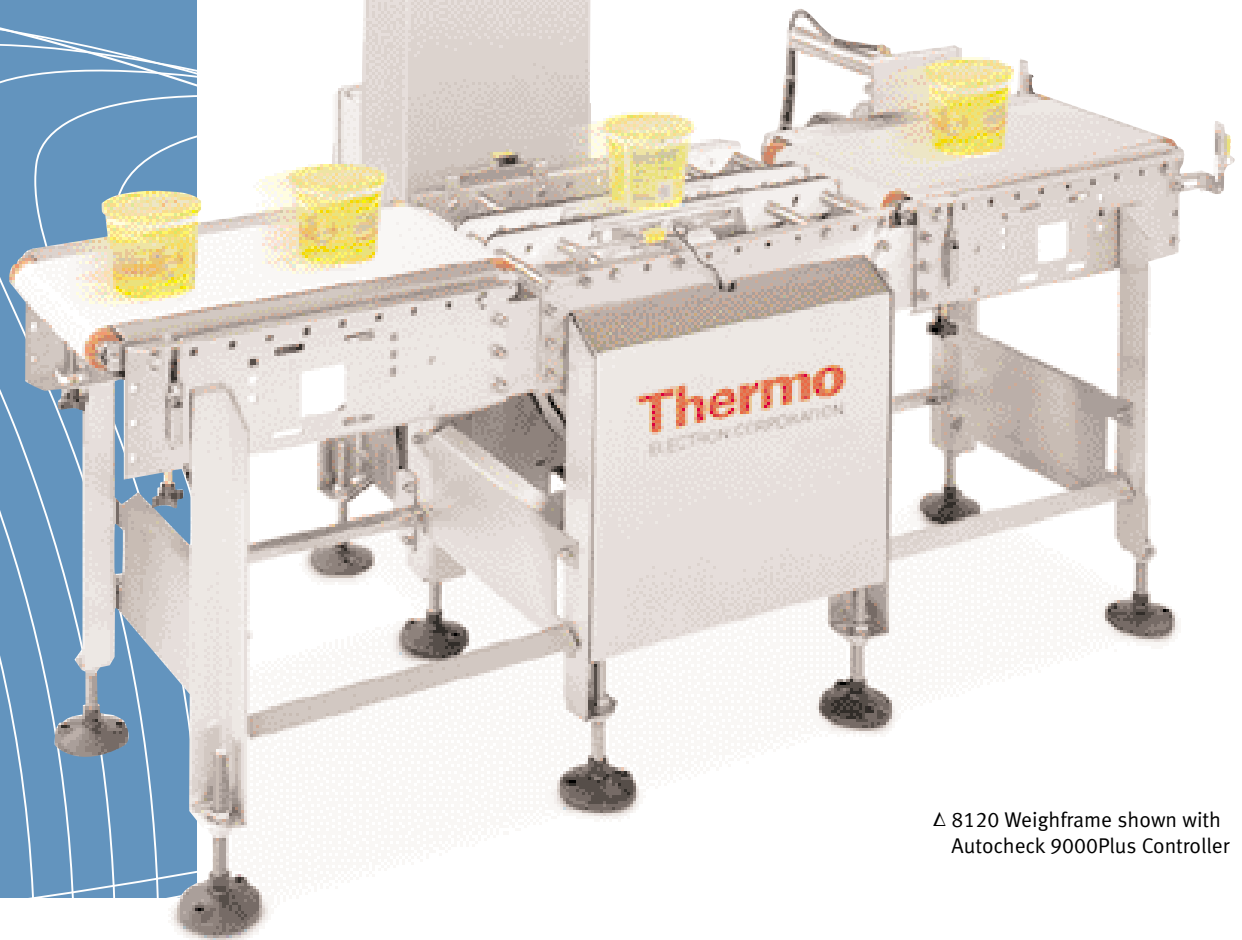

△ 8120 Weighframe shown with
Autocheck 9000Plus Controller

A Stable Foundation For Accurate Checkweighing

- Chain Transport for Optimum Speed and Accuracy
- Designed for Exceptional Performance and Reliability
- Throughput of up to 700 Packages per Minute
- Weighing Capacity up to 11 kg (Individual Product Weight)
- Available with Autocheck 4000i or Autocheck 9000Plus Controller

Features and Benefits

The 8120 weighframe is constructed of 304 stainless steel, with an “open” design that minimizes product build-up and facilitates cleaning. This durable weighframe features a low-maintenance drive system, so there is no gearbox to breakdown or leak. The chain transport system offers faster weighing response than belt-driven checkweighers.

For harsh environments, an available washdown option includes a hermetically sealed loadcell and waterproof drive motor. The 8120 may be ordered with a variety of reject systems such as air jets, pushers, drop gates, or carrier rejects for seamless integration into any production line.

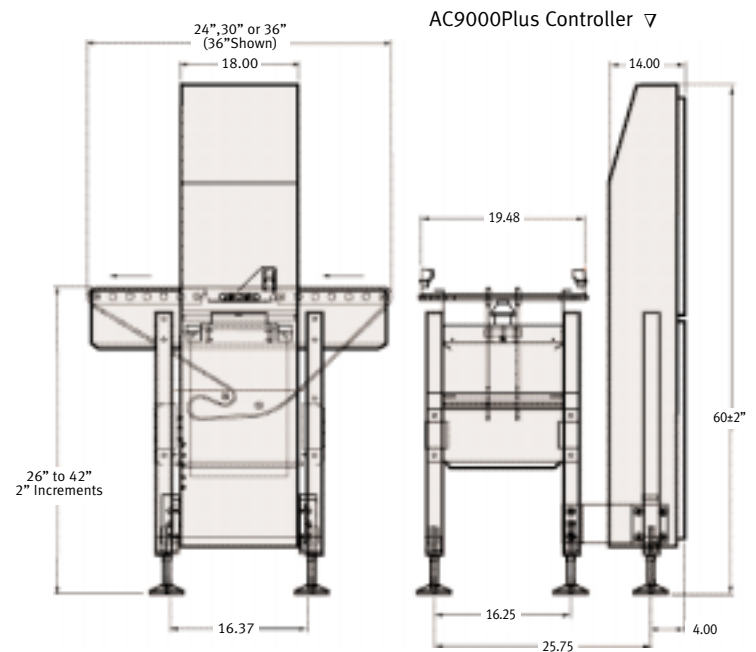

GENERAL SPECIFICATIONS

Compatible Controllers	AC9000Plus or AC4000i
Accuracy (typical) (2 std. deviations from mean)	± 1g Minimum (product/speed dependent)
Line Speed	20 to 550 ft per minute
Throughput	Up to 700 packages per minute
Product Weights	Up to 25 lb (11kg), per product
Frame Construction	304 stainless steel
Drive Motor	Splash-proof standard Sealed washdown optional
Weigh Cell	Splash-proof standard Hermetically sealed optional
Operating Temperature	14 to 122 degrees F -10 to 50 degrees C 0 to 95% humidity
Electrical	115/220VAC + 10%, 50/60 Hz, single phase
Weighframe Dimensions	Length: 24" / 30" / 36" Height: (adjustable in 2" increments) 26" to 42" Width: 19.48"

PRODUCT SPECIFICATIONS

Maximum Product Specifications	Length: 21" (532mm) rate dependent Width: 14" (355mm) rigidity dependent Height: Product-stability dependent
--------------------------------	--

OPTIONS

Transport Media	Nylatron chain for light products Stainless steel chain for heavy products Micropitch chain for high accuracy
Infeed/Outfeed Conveyors	A complete selection of conveyors is available depending on application requirements – consult factory
Available Metal Detector	The 8120 is available with a metal detector as a combo unit
Infeed/Outfeed Conveyors Side Belt Transfer	A complete selection of conveyors and transfer belts are available depending on application requirements – consult factory for details
Washdown Option	Hermetically sealed loadcell and waterproof motor
Emergency Stop	Mushroom push-button



Thermo Electron - Weighing and Inspection offers a wide variety of products and services designed specifically for the packaging industry. Contact Thermo Electron or your sales representative for further information.