

The Ramsey Series 20 Belt Scale System monitors feed to crushers, mills, screens and other processes with an accuracy of $\pm 0.5\%$, even in the harshest applications. The Ramsey Series 20 lets you monitor production output and inventory, or regulate product loadout, while providing vital information for the effective management and efficient operation of your business.

Ramsey Series 20 Belt Scale System

Accurate conveyor weighing of bulk materials



Designed for general in-plant belt conveyor weighing applications in the most demanding industrial environments, Thermo Electron Corporation's Ramsey Series 20 Belt Scale System lets you control feed rates to crushers, mills, screens and other processes with incredible accuracy. It can monitor production output and inventory, or control product loadout, while providing vital information for the management and operation of your business.

The Ramsey Series 20 combines the proven reliability of the Ramsey 10-20 Single Idler or 10-22 Dual Idler Weighbridge and the Ramsey 60-12 Belt Speed Sensor with the power and versatility of the advanced electronics in the Ramsey Micro-Tech 2000 Series or the Ramsey Micro-Tech 3000 Series of electronic integrators.

For more information about the Ramsey Micro-Tech series of electronic integrators, please refer to catalog P18011.0703.

Easy Installation

Easy to install, indoors or out, on fixed or portable conveyors, the rugged construction of the Ramsey Series 20 allows for installation in the harshest applications at a variety of locations.

The Weighbridge

Rigid and rugged, the Ramsey 10-20 and 10-22 Weighbridges remain permanently aligned within the conveyor frame. This one-piece, drop-in style weighbridge is completely assembled at the factory and is quickly and easily installed and aligned properly on the conveyor. It is designed to provide additional stiffening and support to minimize conveyor deflection.

Both the single and the dual-idler models offer three-point suspension and employ trunnion-type, frictionless pivots. These sealed units are impervious to vibration, moisture and product build-up, which eliminates problems commonly associated with knife edges and bearings.

Applications

- Crushing plants
- Chemical plants
- Asphalt plants
- Mines
- Cement mills
- Coal preparation plants
- Paper mills
- Gypsum mills
- Sand and gravel operations
- Coal-fired power plants
- Ore beneficiation processes
- Rail loadouts





Ramsey 10-20 Weighbridge

Ramsey Micro-Tech 2001 Field Mount Unit

Belt Speed Sensor

The Belt Speed Sensor

Thermo's Ramsey 60-12 Digital Belt Speed Sensor is the most reliable and accurate speed-sensing device ever developed for belt scale service. Direct-coupling the sensor to the conveyor tail pulley, snubbing roll, or a large diameter return roller ensures an accurate belt-travel readout. No wheels ride on the belt, which eliminates problems related to material build-up and slippage.

Weighbridge Advantages

- No moving or wearing parts
- Precision strain-gauge load cell applied in tension to guarantee load cell alignment and accuracy
- Total deflection of idler(s) less than 0.102 mm (0.004 in)
- Slim profile to minimize material build-up
- Optional counterweighted carriages for light belt loading applications

Belt Speed Sensor Advantages

- Rugged, cast-aluminum housing suitable for outdoor installations
- A.C. pulse generator means no brushes to adjust or replace

Performance Guarantee

On factory-approved installations, we warrant that the Ramsey Series 20 Belt Scale System will weigh and totalize to a value within $\pm 0.5\%$ of the test value when calibrated against a known test weight, chain, or Thermo's standard electronic calibration.

60-12 Speed Sensor

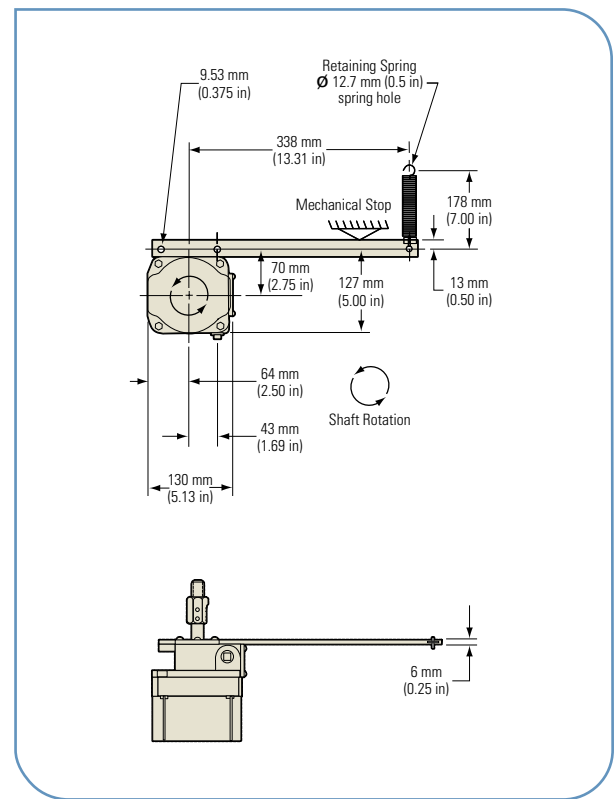

Ramsey 10-20 Single Idler Weighbridge Dimensions

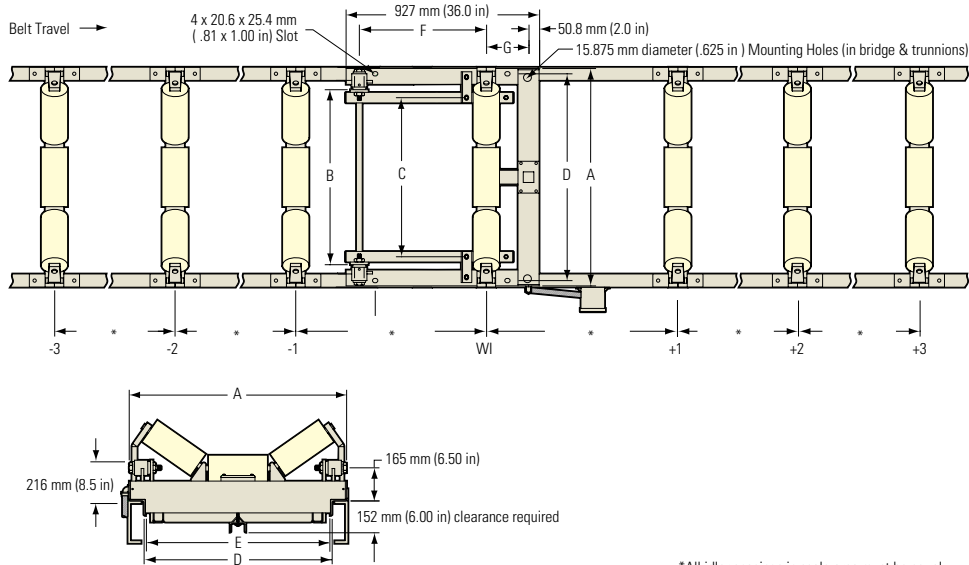

Ramsey Series 20 Single Idler Belt Scale — Variable Belt Width Dimensions

BELT WIDTH	LENGTH (in)						F	G
	A	B	C	D	E			
18	29.00	21.00	18.00	27.00	24.00	24.00	8.00	
20	31.00	23.00	20.00	29.00	26.00			
24	35.00	27.00	24.00	33.00	30.00			
30	41.00	33.00	30.00	39.00	36.00			
36	47.00	39.00	36.00	45.00	42.00			
42	53.00	45.00	42.00	51.00	48.00			
48	59.00	51.00	48.00	57.00	54.00	22.75	9.25	
54	65.00	57.00	54.00	63.00	60.00			
60	71.00	63.00	60.00	69.00	66.00			
72	83.00	75.00	72.00	81.00	78.00			

BELT WIDTH	LENGTH (mm)						F	G
	A	B	C	D	E			
487	737	533	487	686	610	610	203	
508	787	584	508	737	660			
610	889	686	610	838	762			
762	1041	838	762	991	914			
914	1194	991	914	1143	1067			
1067	1346	1143	1067	1295	1219			
1219	1499	1295	1219	1448	1372	578	235	
1372	1651	1448	1372	1600	1524			
1524	1803	1600	1524	1753	1676			
1829	2108	1905	1829	2057	1981			

Ramsey 10-22 Dual Idler Weighbridge Dimensions

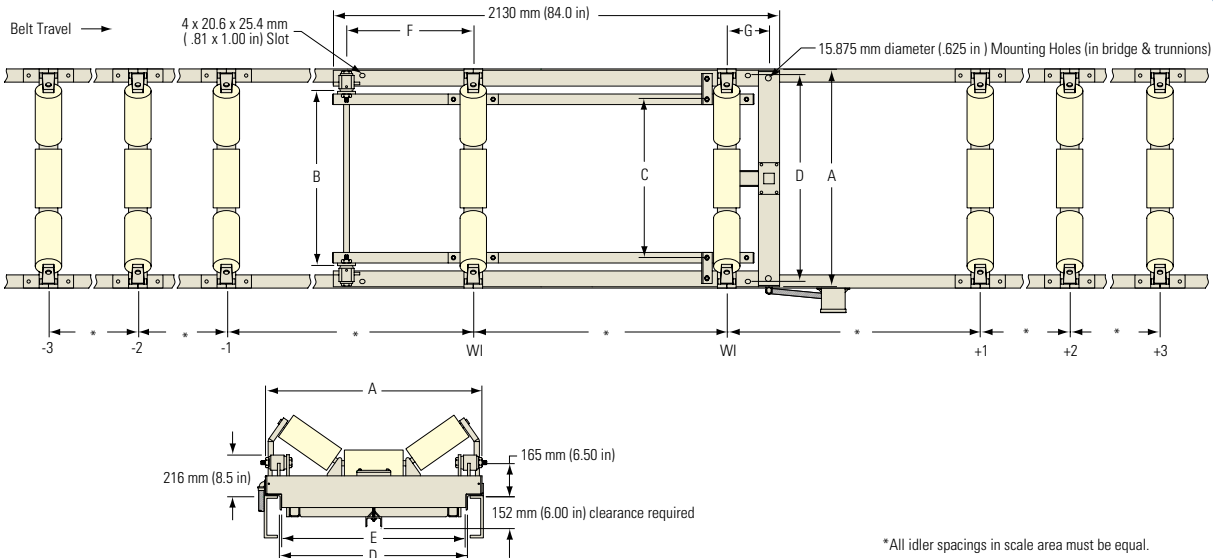

Ramsey Series 20 Dual Idler Belt Scale — Variable Belt Width Dimensions

BELT WIDTH	LENGTH (in)						F	G
	A	B	C	D	E			
18	29.00	21.00	18.00	27.00	24.00	24.00	8.00	
20	31.00	23.00	20.00	29.00	26.00			
24	35.00	27.00	24.00	33.00	30.00			
30	41.00	33.00	30.00	39.00	36.00			
36	47.00	39.00	36.00	45.00	42.00			
42	53.00	45.00	42.00	51.00	48.00			
48	59.00	51.00	48.00	57.00	54.00	22.75	9.25	

BELT WIDTH	LENGTH (mm)						F	G
	A	B	C	D	E			
487	737	533	487	686	610	610	203	
508	787	584	508	737	660			
610	889	686	610	838	762			
762	1041	838	762	991	914			
914	1194	991	914	1143	1067			
1067	1346	1143	1067	1295	1219			
1219	1499	1295	1219	1448	1372	578	235	

Ramsey Series 20 Belt Scale System

Specification	
Ramsey 10-20 and 10-22 Weighbridges	
Weigh Span	One or two idler suspension; Weigh spans from 762 to 1829 mm (30 to 72 in)
Weighbridge Design	Unitized assembly consisting of pivoted weigh platform and one support beam that spans the conveyor stringer; Rugged one-piece design stiffens scale's area of conveyor
Weighbridge Construction	Mechanical steel tubing; Conveyor sizes 457 to 1829 mm (18 to 72 in) or 400 to 2000 mm (15.75 to 78.74 in) belt widths as standard.
Clearance Requirements	Fits any standard conveyor; No space required above belt line. See plan view drawings for deck plate cutout dimensions.
Load Cell	
Quantity	1
Enclosure	Environmentally-protected "S" type cell
Mounting	Tension
Excitation	10 VDC \pm 5%
Output	3 mV/V \pm 0.1%
Non-Linearity	< 0.03% FS
Non-Repeatability	0.01% FS
Hysteresis	< 0.02% FS
Operating Temperature	-54°C to +93°C (-65°F to +200°F)
Temperature Sensitivity	Span 0.0014% FS/°C (0.0008% FS/°F); Zero 0.0027% FS/°C (0.0015% FS/°F)
Overload	Safe to 150% of load cell capacity; Ultimate to 300% FS; Sideload 50% FS
Rating	FM Approved for Class II, Div 1 & 2, Groups E, F & G; NTEP Type III, 5000 divisions; OIML R60
Ramsey 60-12 Digital Speed Sensor	
Type	Digital, brushless
Mounting	Direct to 15.88 mm (0.625 in) diameter stub shaft on tail pulley, bend pulley, or return roll
Housing	Weather-tight, epoxy finish, cast aluminum
Mounting Hardware	Supplied with coupling, restraint arm and restraint spring
Shipping Weight	3.6 kg (8 lb)



©2004 Thermo Electron Corporation. All rights reserved. Specifications, terms and pricing are subject to change. Not all products are available in all countries. Please consult your local sales representatives for details. Literature Code PI.8017.1103

Australia +1 61 (0) 8 8150 5300 +1 61 (0) 8 8234 5882 fax	Germany +49 (0) 208-824930 +49 (0) 208-852310 fax	South Africa +27 (0) 11-609-3101 +27 (0) 11-609-3120 fax	USA +1 (877) 290-7422 +1 (763) 783-2525 fax
Canada +1 (905) 888-8808 +1 (905) 888-8828 fax	Italy +39 02-959514-1 +39 02-953200-15 fax	Spain +34 01-657-3900 +34 91-661-5572 fax	
China +86 (0) 516-7793650 +86 (0) 516-7793652 fax	Netherlands +31 (0) 33-454-9000 +31 (0) 33-454-9009 fax	United Kingdom +44 (0) 1788-820300 +44 (0) 1788-820301 fax	

Process Instruments

www.thermo.com