

The Thermo Scientific DSP Rx metal detector is a superior quality assurance tool designed to GMP (Good Manufacturing Practice) standards. It offers customers the highest standards of sensitivity—with the additional benefits of flexibility, and one of the most advanced quality control systems available. Designed exclusively for the pharmaceutical industry, this system also offers the option of full validation at a most economic price.

DSP Rx

High Performance Metal Detector for the Pharmaceutical Industry



Benefits

- Offers a significant increase in sensitivity using QuadraCoil™ technology
- Guaranteed automatic performance verification with AuditCheck™
- Simplified and cost reduced installation with our extensive validation package
- Manufactured to Good Manufacturing Practice standards

The Thermo Scientific DSP Rx metal detector provides the optimum in quality control for pills and capsules immediately after the pill press or after the capsule filler. By ensuring the absence of metal contamination of product, this metal detector provides the solution to meet the to meet the U.S. Federal Drug Administration's (FDA) stringent requirements for validated production. The patented AuditCheck validation tool ensures consistent sensitivity without the need for manual testing.

The Thermo Scientific DSP Rx incorporates our very latest QuadraCoil (patent pending) technology. This technology leads to increased spherical sensitivity levels up to 20%.

GMP design has eliminated exposed cables and pneumatic pipes leading to an exceptional hygienic design. The unit is available in three standard sizes to ensure that the correct aperture is used for different product sizes and throughputs.



Available Options

- Local, or remote, 80-column printer for reports generation
- Menus available in English, Italian, Spanish, French, Dutch, German, Polish, Finnish, and Czech
- AFS Dual Frequency
- Reject Verification / Bin Full
- Certified Test Spheres
- Communication port: RS232C / RS485
- DSPnet Network Software
- SCADA Protocols:
 - Modbus
 - Device Net
 - Profibus
- ATEX zone 22 certification

Standard Features and Benefits

- **QuadraCoil Technology**
Provides new, higher standards for sensitivity performance in the pharmaceutical industry.
- **AuditCheck Performance Validation**
Ensures optimal performance and reduces operating costs by regular automatic testing using an actual metal sample.
- **Auto Balance and Stable Frequency Control**
Ensures that the sensitivity performance is always at its peak.
- **Touch Panel Key Pad**
Easy equipment setup is ensured with this washdown control panel.
- **Digital Control and Processing**
The all digital control prevents external sources and cable movements from interfering with the signal.
- **Fail Safe Reject Mechanism**
In the event of a power failure, loss of air pressure, or any fault condition, the unit will automatically revert to reject mode for safe and secure production.
- **Product Memory**
The DSP Rx comes standard with a 40-product memory. This allows product effects to be individually optimized. This is especially important in applications where iron-fortified tablets or gel capsules are being inspected. This feature may be used in conjunction with the AFS dual frequency option.
- **Access Code Restriction**
Prevents unauthorized personnel from making changes to the product setup.
- **High Throughput Rates**
Three sizes of product apertures are available to ensure that optimal performance is obtained with rates up to 30,000 tablets per minute.
- **High Operating Frequency**
The DSP Rx can operate up to 1MHz and can be set for optimum sensitivity.
- **Complete Mobility**
Designed to be highly mobile; design includes an easy-to-adjust height and angular feature.
- **Full Stainless Steel Construction**
A mirror-finish, stainless steel construction ensures the best GMP practice, which will withstand aggressive cleaning.
- **Full Validation Documentation**
To reduce installation costs, this metal detector can be supplied with an economic validation documentation package.

Total Quality Solution™ (TQS)

Any metal detector is considered a QA tool. We have built features into the DSP Rx metal detector that provide a unique Total Quality Solution (TQS). TQS has a number of elements:

Reject Validation

High quality metal detection is only as good as the automatic reject mechanism. To ensure that the reject mechanism functions correctly, Thermo has introduced the reject validation option. The validation option monitors the rejected specimen and ensures that it travels into the reject bin. If it does not, then an alarm is generated. Reject validation also takes place during an AuditCheck or Thermo Scientific Quality Test, which gives an early warning of any reject mechanism problems.

AuditCheck—Automatic Performance Verification

AuditCheck is a unique and world-patented device that automatically monitors the sensitivity performance of the metal detector. A test shuttle is pneumatically passed through the head and the resulting signal is compared to calibration data. The test is carried out on a regular, user-defined basis. Any deviation from standard is reported, and the operator can take appropriate remedial action. Small changes due to product effect can be identified early for re-calibration. These detected changes reduce cost by eliminating downtime and re-work.

Studies have shown that AuditCheck offers considerable savings as a result of reduced manual testing and reduction, or elimination of, product quarantine and re-work. The AuditCheck test results are reported and printed as required.

Thermo Scientific Quality Test

The Thermo Scientific Quality Test is a mechanism that ensures manual tests are carried out at the prescribed times. The operator is prompted to pass test spheres through the head at the appropriate time. If these are correctly rejected, the test is considered to be satisfactory and an appropriate report is generated. If the test fails to be completed in an appropriate timescale, an alarm will be generated.

Good Manufacturing Practice (GMP)

GMP was used in the development and manufacture of the DSP Rx in order to meet the stringent requirements of the pharmaceutical industry. Some of the unique features incorporated within this metal detector are:

- All cables and pneumatics are routed internally and are not exposed
- Surfaces are sloping and mounting bars are round to prevent powder build up
- All pneumatic controls are internal to the control box
- Mirrored finish for easy cleaning and easily identified contaminant
- Open construction eliminates possible product traps

Validation Option

The DSP Rx is validated in compliance with standard FDA rules. This ensures that the customer's cost of installation is minimized. The validation process consists of the following:

- **Project Plan**
The plan presents the Thermo Fisher Scientific organizational chart and the responsibility of supply.
- **Manufacturing Standards**
The manufacturing procedures, material specifications, and supplier qualification are specified.
- **Test Procedures**
A Factory Acceptance Test (FAT) schedule is defined and the test results are tabulated and certified.
- **Mechanical Drawings and Electrical Schematics**
A complete Bill of Materials (BOM) is provided with a general layout drawing of the metal detector. Spare parts lists are supplied with the electrical schematics of the machine.
- **Software**
Flow charts of the software and source code (as appropriate) are documented. A procedure for software maintenance is also included in this section.

Aftermarket Services

A full range of aftermarket services is available to support the DSP Rx metal detector throughout its lifetime, including commissioning and validation at the time of installation. A full range of operating and maintenance training modules are available either on-site, or at one of Thermo Fisher's worldwide training facilities.

To ensure maximum operational efficiency, we offer on-site maintenance contracts and a complete, spare-parts service.



DSP Rx

General Specifications

Operating Temperature	-10°C to +40°C (+14°F to +104°F)
Relative Humidity	20% to 80% non-condensing
Electrical Supply	85 volts to 260 volts AC single phase plus earth; 47 Hz to 70 Hz; 35 watts maximum
Air Supply	5.5 bar (80 psi)
Outputs	5 Relays (2 optional Solid State Relays); 250 volt AC 1 amp max.; 50 volt DC 1 amp max.
Output Allocation	Reject 1; Reject 2; AuditCheck; Fault; Alarm; QA Lamp
Inputs	5 Optically Isolated Active 12v DC 2k input resistance with negative logic; +12 volt auxiliary supply for input sensors
Input Allocation	Keylock; Product Select; Reject Confirmation 1 (bin full); Reject Confirmation 2; External Suppression
Serial Port (option)	Configurable: RS232 / RS485
Approvals	CE and cCSAus
Manufacturing Quality	ISO9001 certified

DSP Rx — Physical Dimensions

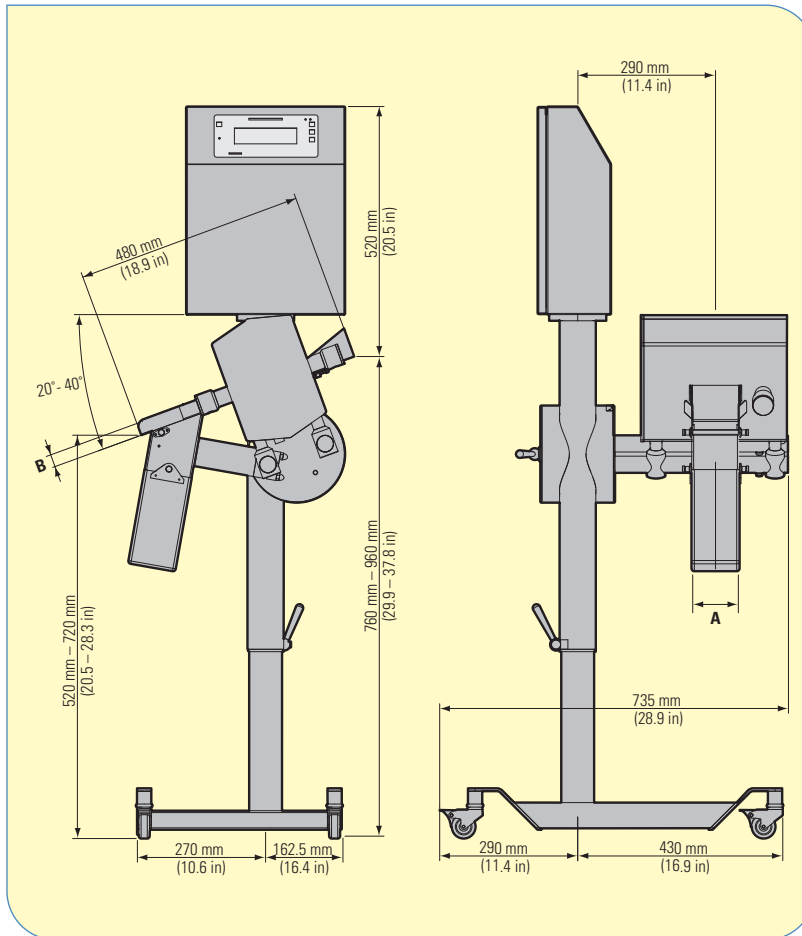

Variable Dimensions

HEAD SIZE (mm)	EFFECTIVE APERTURE (mm)	
	A	B
70 mm x 20 mm	57 mm	9.5 mm
100 mm x 25 mm	87 mm	14.5 mm
150 mm x 35 mm	137 mm	19.5 mm

HEAD SIZE (in)	EFFECTIVE APERTURE (in)	
	A	B
2.75 in x 0.79 in	2.24 in	0.37 in
3.94 in x 0.98 in	3.43 in	0.57 in
5.91 in x 1.55 in	5.39 in	0.77 in

©2007 Thermo Fisher Scientific Inc. All rights reserved. All trademarks are the property of Thermo Fisher Scientific Inc. and its subsidiaries. Results may vary under different operating conditions. Specifications, terms and pricing are subject to change. Not all products are available in all countries. Please consult your local sales representatives for details. Literature Code PL1011.0307

Argentina +54 (0) 11 4334 3827 +54 (0) 11 4334 9159 fax	France +33 (0) 160 92 48 00 +33 (0) 160 92 49 00 fax	Mexico +52 (01) 55 5638 0237 +52 (01) 55 5639 2227 fax	United Kingdom +44 (0) 1788-820300 +44 (0) 1788-820301 fax
Australia +61 (0) 8 8150-5300 +61 (0) 8 8234-5882 fax	Germany +49 (0) 208-824930 +49 (0) 208-852310 fax	Netherlands +31 (0) 76-579-5555 +31 (0) 76-571-4958 fax	United States +1 (800) 227-8891 +1 (763) 783-2525 fax +1 (763) 783-2500 direct
Canada +1 (905) 888-8808 +1 (905) 888-8828 fax	India +91 (20) 6626 7000 +91 (20) 6626 7001 fax	Poland +48 (0) 22 651 75 30 +48 (0) 22 651 75 35 fax	
Chile +56 (0) 2-335-3388 +56 (0) 2-335-1590 fax	Italy +39 05 217886-1 +39 05 212729-14 fax	South Africa +27 (0) 11-609-3101 +27 (0) 11-609-3110 fax	
China +86 (0) 21 6865 4588 +86 (0) 21 6445 1101 fax	Malaysia +60 (0) 3 6203 1957 +60 (0) 3 6203 1963 fax	Spain +34 91-484-5954 +34 91-661-5572 fax	