

HAAKE PCR-630 Process Control Rheometer

The HAAKE PCR-630 is the latest generation of innovative process control technology from Thermo Electron Corporation for on-line rheological measurements of Melt Index and Viscosity. Its patented bypass pump design is especially suited for fractional and low Melt Index polymers, as well as applications sensitive to residence time. The PCR-630 is the fastest bypass rheometer design available and provides near real-time data with its slit die design and 3 independently driven and controlled melt pumps.

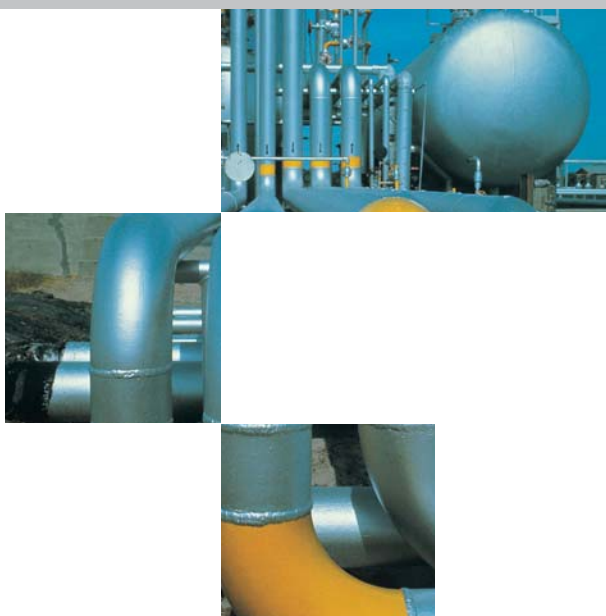

Applications:

- On-Line Melt Index measurement
- On-Line viscosity measurement

Materials:

- Polypropylene (PP)
- Polyethylene (LDPE/HDPE/LLDPE)
- Polyester (PET)
- Ethylen Vinyl Acetate (EVA)
- Polymethyl-methacrylate (PMMA)
- Polystyrene (PS)
- Polyamide / Nylon (PA)
- Polycarbonate (PC)

Applications

The HAAKE PCR-630 (Process Control Rheometer) measures the Melt Index at standard ASTM loads and still maintains a minimal lag time which remains almost constant over the Melt Index measurement range. The PCR-630 is based on the same patented design as the PCR-620. The slit die pressure control feature allows the PCR-630 to operate at pressures above the process pressure, thereby ensuring operation in the linear region of the transducers and preventing out-gassing. This also allows the PCR-630 to cover a wide Melt Index range and follow transitions with a single die, eliminating costly and troublesome die changes common to other systems.

The patented bypass design makes it possible to measure the viscosity at low shear rates without compromising residence time, this results in a much higher sensitivity when comparing different molecular weight

materials. The PCR-630 can operate in a variety of modes: Melt Index mode, Transition Melt Index mode, Purge mode, Viscosity mode (stress control), and combinations of those. The PCR-630 can also report a synthesized Mooney or Intrinsic Viscosity (IV) by mathematical calculation from measured shear viscosity data. For ease of operation, recipes consisting of operating parameters and control values, can be stored for various product grades. The PCR-630 logs all data and events in a database for trend analysis, SPC reporting and data storage.

The PCR-630 is a "return to stream" design and is available with a valve block for process isolation and an optical block to allow on-line spectroscopic analysis (offered as options, additional equipment required). All melts pumps and slit dies are easily exchangeable to adapt the PCR-630 to specific processes.

HAAKE Rheometer

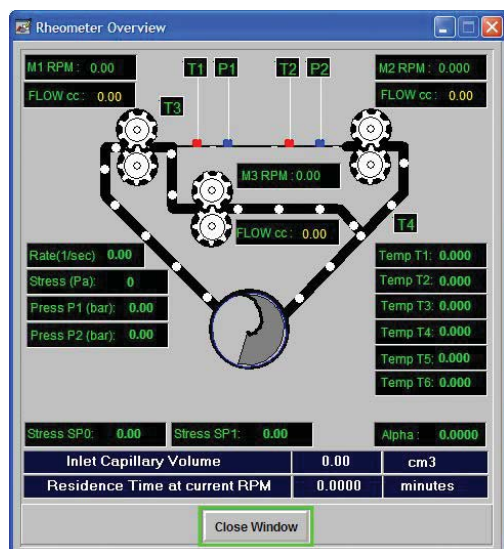

Control Features

The PCR-630 electronics, based on the SLC-500 PLC from Rockwell International (Allen-Bradley), provides superior support and integration using industry standard components and technologies. New software features provide capabilities never before available.

The NEW Process Supervisor for Windows software, available for the PCR-630 and PCR-620, offers unmatched ease-of-use and an operator friendly design. The software, based on RSView32, is designed for integration into plant DCS systems. It offers data communication with a variety of protocols like, Data Highway plus, ModBus and the latest innovation in process control, OPC (OLE for Process Control). Standard analog signals (4-20 mA or 24 VDC) are available also.

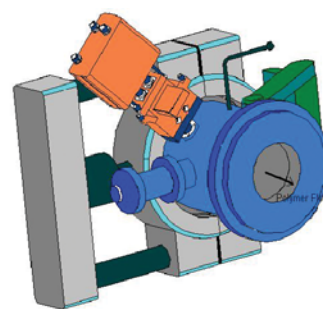

Technical Specifications HAAKE PCR-630

Stress	5 kPa to 250 kPa
ASTM D-1238 loads	0.5 Kg to 25 Kg
Shear Rate	0.03 to 4,000 1/sec
Viscosity	2 to 240,000 Pa.s 20 to 2,400,000 poise
Melt Flow Index	0.02 to 3,000
Temperature	50°C to 350°C (400°C option)
Pumps	Rheometer: 0.584 cc/rev to 1.752 cc/rev Bypass: 1.752 cc/rev to 2.92 cc/rev Max. Speed: 60 rpm
Pressure Transducers	100 bar to 350 bar (1500 psi to 5000 psi)
Slit Dies	Height 0.03 cm to 0.2 cm Width 2.25 cm to 1.2 cm Length 4 cm to 8 cm
EX proof on request	
Power	220 VAC, 30A, single phase, 50/60 Hz
Weight	Rheometer: 115 kg (250 lbs) Electronics: 43 kg (95 lbs)

Installation & Maintenance

Installation expertise exists for adaption to extruders from all the major manufacturers. The PCR-630 is typically installed on finishing and compounding extruders upstream to a pelletizer or mounted as a side stream with a piping adapter. It can be retrofitted to many existing process systems. The PCR-630 is interchangeable with existing PCR and MFM installations as an upgrade option.

The PCR-630 is backed-up by a worldwide, direct support system for service and training of plant personnel. Thermo also provides services to assist with the integration of the PCR-630 in plant DCS systems. The PCR-630 design concept provides superior ease of maintenance features with its design concept and easy access to all critical components.

The PCR-630 can be removed from the process by closing its isolation valves and removing only 2 bolts. The vast majority of maintainable components are standard stock items from major vendors of polymer processing hardware.

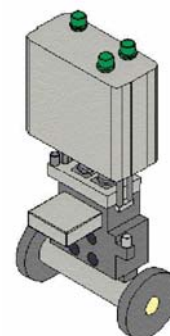
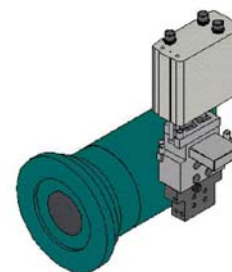

Thermo Electron Corporation

Material Characterization Business

International/Germany

Thermo Electron (Karlsruhe) GmbH
Dieselstr. 4
76227 Karlsruhe
Tel. +49(0)721 40 94-444

Benelux

Thermo Electron B.V.
Takkebijsters 1
4817 BL Breda
Tel. +31(0)76 5879888

France

Thermo Electron S.A.
16 Avenue du Québec - Silic 765
91963 Courtaboeuf Cedex
Tel. +33(0)1 60 92 48 00

Thermo Electron UK

Emerald Way
Stone Business Park, Stone
Staffordshire ST15 0SR
Tel. +44(0)1785 813648

USA

Thermo Electron
25 Nimble Hill Rd.
Newington, NH 03801
Tel. 603-430-6329

info@thermoahaake.com