

Thermo Scientific Ramsey Micro-Tech 3000

Electronic Instruments for Static Weighing

The Thermo Scientific Ramsey Micro-Tech 3000 series of electronic instruments signifies a new approach to scale instrumentation, giving you more flexibility and vastly increased upgrade capabilities. Each model is designed for your specific weighing application, and because they utilize a common platform, you only need to become familiar with one basic interface.

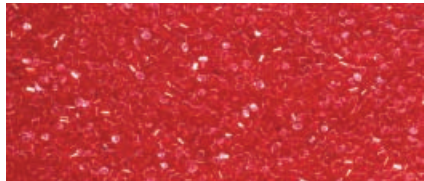

The Thermo Scientific Ramsey Micro-Tech 3000 series of instruments is suitable for production/consumption monitoring and control in many industries such as mining, cement, coal, ceramics, food, chemicals and more, for applications utilizing:

- Load cell static weighing systems
- Grain overload controls
- Multi-component static batch weighers and feeders

Features Common to All Models

- Dual language (English/Second language). Second Language can be Spanish, French, German, Dutch, and Italian. Chinese (Mandarin) available on some versions only.
- Automatic conversion of data between Metric and English measure units
- 24 bits A/D converter (more than 16,000,000 intervals)
- Plug-and-play add-in boards recognition
- Audit trail
- Self diagnostics, alphanumeric alarm messages
- Panel mount and field mount versions
- Battery back-up clock calendar for time and date monitoring and printing

The Ramsey Micro-Tech 3000 is designed to meet your specific weighing application and is available in five models.

Weight Indicator Model 3100

The model 3100 is a weight indicator/transmitter for static scales designed for accurately weighing materials in industrial applications. When equipped with optional add-in boards, the 3100 can control up to four independent weighing points. This model has three available internal slots for optional expansion boards.

Weight Indicator Model 3200

The model 3200 is similar to the model 3100, but it is suitable for approval under HB44 and OIML standards. This version uses an add-in premium A/D board to achieve superior accuracies. The model 3200 has two available internal slots for optional expansion boards.

Batch Feeder Controller Model 3102

The model 3102 is a static weighing and batching unit able of managing up to 40 ingredients with 100 recipes (batching programs). The system provides independent totalizers for each ingredient and for each recipe. When equipped with optional add-in boards, the 3102 can control up to four independent weighing points. The system controls the batching and discharging time, the preset weight, the queue of material at the end of

the batch, and can automatically correct the batch accuracy. The system can run the same recipe on the four scales, or four recipes, one per each scale. Printing is provided for recipes, batch, and other process data. This model is equipped with one digital output board (16 outputs, four inputs), and has two available internal slots for optional expansion boards.

Batch Feeder Controller Model 3202

The model 3202 is similar to the model 3102, but it is suitable for approval under HB44 and OIML standards. This model is equipped with one digital output board and one premium A/D add-in board, and has one internal slot available for an optional expansion board.

Auto-Mat Model 3108

The Auto-Mat model 3108 is a static weighing unit specifically designed for automatically calibrating dynamic scales, such as conveyor belt scales and weighbelt feeders. The 3108 accurately measures the static weight of material before or after it is weighed by the dynamic scale, and corrects the span factor of the dynamic scale integrator (3101, 3201 or 3105) by sending the correction factor via a serial communication line. This model has three available internal slots for optional expansion boards.



All set-up, calibration and diagnostic functions are performed via the front panel display and keyboard. Menu driven software makes the unit easy to use, with comprehensive messages and set up procedures, which minimizes human errors.



Ramsey Micro-Tech 3000 Field Mount

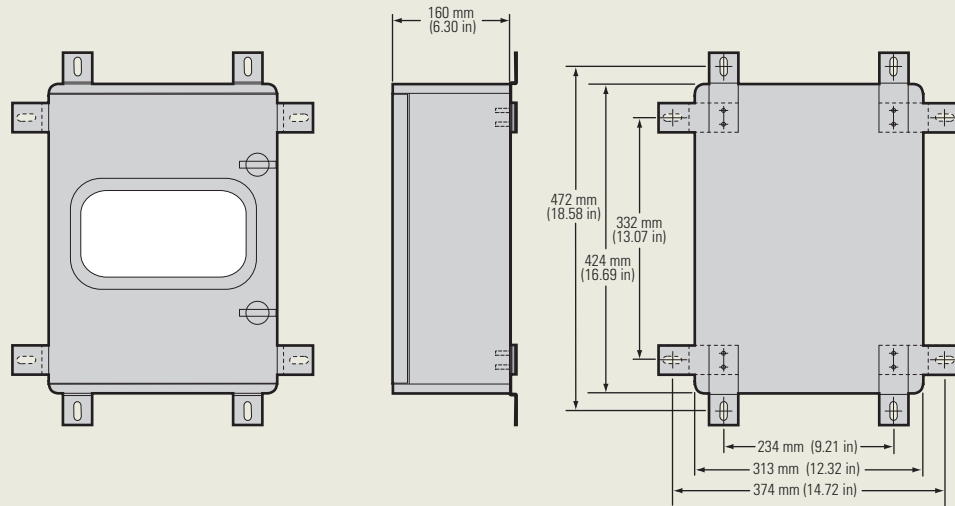

Ramsey Micro-Tech 3000 Panel Mount

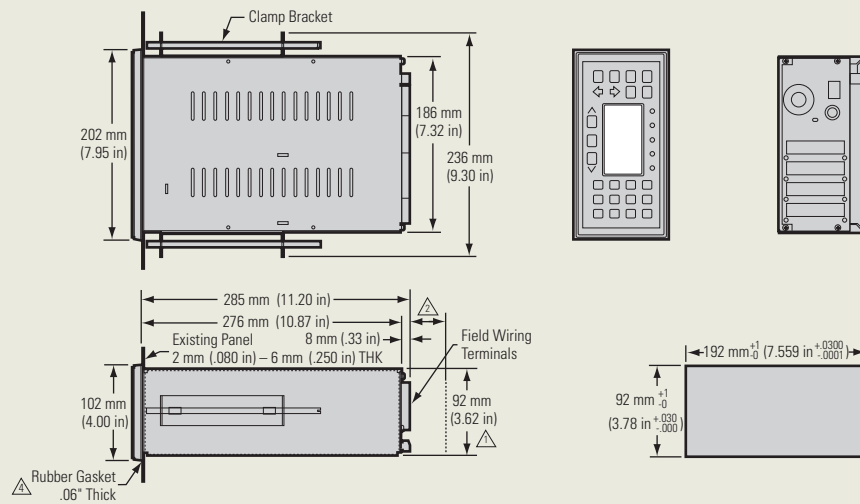

Thermo Scientific Ramsey Micro-Tech 3000

Software

Calibration	Automatic calibration of zero and span Zero tracking Guided calibration procedures 10 points linearization Multiple zero and span calibration points
Totalizers	Two independently resettable internal totalizers
Alarms	Load cell failure Internal failures Several process alarms, such as low and high weight, etc.
Communications and Printer	Through the built-in communication port, the system can print process variables, totaled quantities of material, alarms and set up data. When configured in RS-485 mode, the communication port can be used to connect with another intelligent device. The default communication protocol is Modbus RTU in slave mode. Optional add-in boards are available for field-bus connection. Typical options are AB Remote I/O and PROFIBUS DP. For other field-bus connections, please contact our representatives.

Thermo Scientific Ramsey Micro-Tech 3000

Hardware

Panel Mount Housing	Dimensions: DIN 43700 size 192 x 96 mm (7.56 x 3.78 in), depth 271 mm (10.67 in) Weight: 4 kg (9 lb) Protection: front panel IP55, all housing IP00
Field Mount Housing	Reinforced fiberglass housing Dimensions: 310 x 425 x 160 mm (12.2 x 16.73 x 6.3 in) Weight: 10.2 kg (21 lb) Protection: IP65 (NEMA 4/4X)
Instrument Front	23 keys membrane keyboard Graphical LCD display emulating 4 lines of 20 characters 5 LEDs
Power Supply	Selectable 110/220 Vac or 120/240 Vac \pm 10%, 50/60 Hz
Environmental Conditions	Operating temperature -10°C to +50°C (+14°F to +122°F) Storage temperature -40°C to +70°C (-40°F to +158°F)
Computer	32 bits Motorola® CPU 64 KB RAM with lithium battery back-up 256 KB EPROM 8 KB EPROM
Load Cell Input	Power for up to six 350 Ohm load cells in parallel Nominal Input Signal: 3.5 mV/V, Max 35 mV bipolar Low-pass and Power Supply filters Sigma-delta A/D converter, more than 16,000,000 divisions
Digital Inputs	Four opto-coupled programmable inputs, expandable with optional add-in boards
Digital Outputs	Five relay outputs, suitable for 24 Vac/dc 5 Amps, of which one is dedicated to System Fail and one to the Remote Totalizer pulse signal (3104 only).
Analog Output	One opto-coupled analog output programmable for 0-20 mA/4-20 mA or 20-0 mA/20-4 mA
Communications	One isolated RS232, RS485 or 20 mA communication port

Expansion Slots

Number of Slots	Three on base unit – the number of effectively available slots depends upon the model as specified. <i>Expansion slots can be used to install any combination of the following optional boards.</i>
Current Output Board-Type A	One 12 bit isolated analog output, programmable for 0-20 mA/4-20 mA or 20-0 mA/20-4 mA
Current Output Board-Type B	Two 12 bit isolated analog output, programmable for 0-20 mA/4-20 mA or 20-0 mA/20-4 mA and two analog inputs.
Plant Scale A/D Board	One weight input channel
Dual Plant Scale A/D Board	Two independent weight input channels
Premium A/D Board	One High Precision weight input channel
Serial Communication Board	One isolated RS232, RS485 or 20 mA communication port
Profibus Board	One PROFIBUS DP field bus channel
AB RIO Board	One Allen-Bradley® Remote I/O field bus channel
Digital Input Board	16 opto-coupled inputs and four open collector opto-coupled outputs
Digital Output Board	Four opto-coupled inputs and 16 open collector opto-coupled outputs
PFM Board	One Pulse Frequency Modulated input channel
Frequency Output Board	One frequency output

©2007 Thermo Fisher Scientific Inc. All rights reserved. Motorola is a registered trademark of Motorola, Inc. in the United States. Allen-Bradley is a registered trademark of Rockwell Automation in the United States. Results may vary under different operating conditions. Specifications, terms and pricing are subject to change. Not all products are available in all countries. Please consult your local sales representatives for details. Literature Code PL8012.1207

Australia
+61 (0) 8 8208 8200
+61 (0) 8 8208 8300 fax

Canada
+1 (905) 888-8808
+1 (905) 888-8828 fax

Chile
+56 (0) 2-335-3388
+56 (0) 2-335-1590 fax

China
+86 (0) 21 6865 4588
+86 (0) 21 6445 7830 fax

Germany
+49 (0) 208-824930
+49 (0) 208-852310 fax

India
+91 (20) 6626 7000
+91 (20) 6626 7001 fax

Italy
+39 02-959514-1
+39 02-953200-15 fax

Netherlands
+31 (0) 33-454-9000
+31 (0) 33-454-9009 fax

Poland
+48 (0) 22 651 7530
+48 (0) 22 651 7535 fax

South Africa
+27 (0) 11-609-3101
+27 (0) 11-609-3110 fax

Spain
+34 (0) 91 484 59 65
+34 (0) 91 484 35 97 fax

United Kingdom
+44 (0) 1788-820300
+44 (0) 1788-820301 fax

United States
+1 (800) 227-8891
+1 (763) 783-2525 fax
+1 (763) 783-2500 direct

www.thermo.com/bulk-handling