

The Thermo Scientific APEX 100 metal detector provides basic, cost-effective protection from the most common metal contaminants found in food production today. It is designed and built using the same core technology as the industry-leading, high performance Thermo Scientific APEX 500.

Thermo Scientific APEX™ 100

Economical metal detector for package and process applications



Features and Benefits

- Sensitivity matching the Thermo Scientific DSP 3 and Metal Eliminator detectors
- Compact and robust mechanical design makes installation easy and provides for years of reliable operation
- Unique icon driven interface with multilingual Help and Autocalibrate functions
- Dual frequency operation for application flexibility
- Available with Thermo Scientific conveyor systems designed to your specifications

The Thermo Scientific APEX 100 metal detector provides protection from many types of metal contaminants encountered in food production today. It offers basic magnetics, electronics and software technology developed for the high-performance Thermo Scientific APEX 500 metal detector. By offering only the most commonly required metal detection capabilities, the APEX 100 delivers outstanding value.

Supported by the Thermo Fisher Scientific global service network, the APEX 100 meets the reliability, environmental and hygienic needs of the food industry. It has been designed for failsafe operation and has been fully tested to meet IP65/NEMA4/ATEX requirements. Only food-grade materials are employed in construction including the stainless steel case and ABS control panel.

Available APEX 100 options include mounting kits to convert from a DSP metal detector to an APEX, field compression flanges, certified test pieces, reject verification/bin full sensors and a wide variety of customized conveyor systems.

We provide advanced analytical instruments for the food, pharmaceutical and beverage industries in the lab and on the production line. With over 50 years of experience providing high-quality, cost-effective contaminant detection systems, we are recognized as a world leader. Our solutions include many models of metal detectors for a variety of applications, as well as a full line of X-ray inspection systems.

Thermo Scientific APEX™ 100 Metal Detector

General Specifications

Construction	Stainless steel 304 straightlined case, ABS plastic control panel
Protection Ratings	IP 65, NEMA 4, ATEX zone 22, hazardous location Class II Division 2 Groups F&G
Operating Temperature	-10°C to +40°C (+14°F to +104°F)
Relative Humidity	20% to 80% non-condensing
Electrical Supply	85 volts to 260 volts AC single phase plus earth ground; 47 Hz to 65 Hz, 100 watts maximum
Product Speed	0.5 m/min (1.7 ft/min) to 1000 m/min (3,300 ft/min)
Outputs	6 Relays outputs; Relays: 250 volt AC 2 amp max. 50 volt DC 1 amp max.
Output Allocation (selectable via menu)	Reject 1, Reject 2, Fault, Alarm, Warning, QA lamp
Inputs	6 Inputs - Active 12v DC+12 volt auxiliary supply for input sensors
Input Allocation (selectable via menu)	Speed Sensor, Keylock, Product Select 1, Product Select 2, Infeed PEC, Reject Confirmation 1 (bin full), Reject Confirmation 2, External Suppression
Safety and Export Approvals	cCSAus, CE, ATEX zone 22
Manufacturing Quality	ISO9001 certified
Help-Text, Users Manual Languages	English, Spanish, French, German, Italian, Dutch, Chinese, Russian, Czech

APEX 100 Metal Detector dimensional diagram

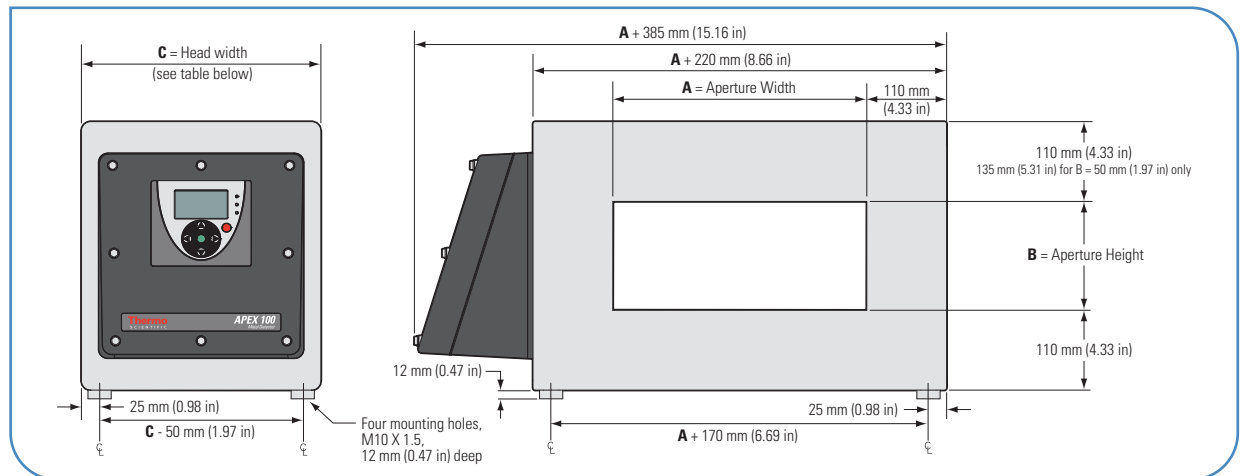

APEX 100 case width (C) dimension in millimeters

		Aperture Width (A)										
		150 (5.9)	200 (7.9)	250 (9.8)	300 (11.8)	350 (13.8)	400 (15.7)	450 (17.7)	500 (19.7)	550 (21.6)	600 (23.6)	650 (25.6)
Aperture Height (B)	100 (3.9)	295	295	295	295	295	295	295	295	295	295	295
	125 (4.9)	295	295	295	295	295	295	295	295	295	295	295
	150 (5.9)	295	295	295	295	295	295	295	295	295	295	295
	175 (6.9)		295	295	295	295	295	295	295	295	295	295
	200 (7.9)		295	295	295	295	295	295	295	295	295	295
	250 (9.8)			330	330	330	330	330	330	330	330	330
	300 (11.8)				330	330	330	330	330	330	330	330
	350 (13.8)					380	380	380	380	380	380	380
	400 (15.7)						380	380	380	380	380	380
	450 (17.7)							380	380	380	380	380

© 2008 Thermo Fisher Scientific Inc. All rights reserved. All trademarks are the property of Thermo Fisher Scientific Inc. and its subsidiaries. Results may vary under different operating conditions. Specifications, terms and pricing are subject to change. Not all products are available in all countries. Please consult your local sales representatives for details. Literature Code PL0048.0508

Argentina
+54 (0) 11 4334 3827
+54 (0) 11 4334 9159 fax

Australia
+61 (0) 8 8208 8200
+61 (0) 8 8234 3772 fax

Canada
+1 (905) 888-8808
+1 (905) 888-8828 fax

Chile
+56 (0) 2-335-3388
+56 (0) 2-335-1590 fax

China
+86 (0) 21 6865 4588
+86 (0) 21 6445 1101 fax

France
+33 (0) 160 92 48 00
+33 (0) 160 92 49 00 fax

Germany
+49 (0) 208-824930
+49 (0) 208-852310 fax

India
+91 (20) 6626 7000
+91 (20) 6626 7001 fax

Italy
+39 05 217886-1
+39 05 212729-14 fax

Malaysia
+60 (0) 3 5122 8888
+60 (0) 3 5121 8899 fax

Mexico
+52 (01) 55 5638 0237
+52 (01) 55 5639 2227 fax

Netherlands
+31 (0) 76-579-5555
+31 (0) 76-571-4958 fax

Poland
+48 (0) 22 651 75 30
+48 (0) 22 651 75 35 fax

South Africa
+27 (0) 11-609-3101
+27 (0) 11-609-3110 fax

Spain
+34 (0) 91-484-5965
+34 (0) 91-484-3597 fax

United Kingdom
+44 (0) 1788-820300
+44 (0) 1788-820301 fax

United States
+1 (800) 227-8891
+1 (763) 783-2525 fax
+1 (763) 783-2500 direct