

The Thermo Scientific AC9 GP Combination Checkweigher/Metal Detector unit offers the most compact solution to end-of-line inspection applications. The system has an extremely small footprint and is easy to install into existing and new production lines. The design takes into account the hygiene and washdown requirements of the food and allied industries, providing a reliable and easy to use machine.

Thermo Scientific AC9 GP Combination

Combines a checkweigher and metal detector on a single frame



The Thermo Scientific AC9 GP Combination is an efficient and space saving solution for end-of-line inspection and quality assurance primarily intended for the food and consumer industries.

This unit has an open construction, which directly addresses and resolves one of today's top concerns in the food industry—namely hygiene and the ability to easily and effectively clean equipment.

By combining the functions of both metal detection and checkweighing on a single cantilevered frame, the line space requirement is reduced to a minimum and makes installation into existing plants simple and efficient at the minimum cost.

The Thermo Scientific AC9GP checkweigher uses weighing principles that have been developed over more than 50 years by the company that was one of the founders of the checkweighing industry. The checkweigher is approved to OIML51 and will operate in 3 zone minimum weight, or EU average weight, mode.

The metal detector used is the Thermo Scientific DSP IP Plus, which is unique in having the severe washdown certification IP 69k. The metal detector has a minimal foot print with good metal free zone characteristics which allows the overall length of the combination unit to be less than 1600 mm (63 in). The metal detector can optionally incorporate the unique and patented AuditCheck, which validates the performance of the metal detector on an automatic and regular basis.



Introduction

The use of inspection equipment within the food, consumer, and allied industries demands the highest standards of hygiene, performance, and reliability. This checkweigher/metal detector unit meets and exceeds these requirements and is uniquely designed and constructed for these applications.

The unit is a cantilevered design, constructed primarily of stainless steel. The use of FDA approved plastic conveyor beds greatly enhances the hygiene and washdown characteristics of the unit.



The machine unit is capable of weighing products from 20 g to 2 kg and speeds up to 300 ppm dependent on the weight and size of the pack. Dependent on pack size and speed, accuracies as low as ± 100 mg (one sigma) are possible. Typical metal detection sensitivities are as low as 0.8 mm ferrous depending on the aperture size and product being inspected.

The combination unit ensures brand protection and at the same time improves process efficiency.

Weigh Table Features

In any checkweigher the performance will be determined by the design of the weigh table. The unique FDA approved plastic conveyor beds improve weighing efficiency and reliability. All conveyors in the range use brushless DC motors, which ensure high levels of reliability. The exceptional torque produced by this type of motor will ensure excellent speed control and weighing accuracy.

Automatic Reject Features and Options

Metal rejects are signaled from the metal detector to the checkweigher controller, which ensures that contaminated products are rejected into a separate lockable bin. Contaminated products will not be included in the weight statistics but will be totaled.

A variety of automatic reject mechanisms are available to provide the optimum solution for each application. Air blast rejects are available for products up to 200 g. A pusher is used for products up to 2 kg and other options are available for specific applications.

Two independent plastic lockable reject bins can be provided for the secure handling of non-standard products. Non-standard weights and contaminated products are placed into separate bins.

Reject validation is available as an option to guarantee the most secure operation and can be operated in the accept stream or the reject stream. A consecutive rejects alarm indicates if there are more than "n" consecutive rejects.

DSP IP Plus

IP69K certification
for high-pressure washdown



AC9 GP Checkweigher

Reduced Cost of Maintenance

The conveyors used on the Ramsey AC9 GP are simply removed for maintenance and cleaning processes without the need for tools. The end rollers flip up so that the belts can be released for cleaning, or replacement. For minimum downtime spare conveyors can be held in inventory due to the standard nature of the design. In the unlikely event of a conveyor failure it takes less than 2 minutes to replace the conveyor.

AuditCheck

AuditCheck is a unique and patented automatic validation device for the metal detector. One of the key aspects of metal detection quality control is the regular testing of the detector. This involved an operator passing test pieces through the unit on a regular basis (typically every hour). This is costly in terms of staff time and can also cause interference with the packaging operation.

AuditCheck is a device that automatically passes a test sphere through the unit and compares the resultant signal with calibration standards. Not only does it indicate metal detection failure but also minor changes in performance.

AuditCheck can potentially save operating costs and may increase profitability. It also helps to protect your brand by ensuring that testing is done on a regular basis.

Low Cost of Ownership

A feature of the unit is the low cost of ownership. In addition to the ease of maintenance and high reliability, the flexibility of the design ensures that changes in the line layout can be accommodated. The line height of the unit is simply adjusted in just a few minutes. Due to the modular design, a different weigh conveyor can be replaced to accommodate alternative product sizes easily.

Total Line Integration

In modern processing factories there is a continued move towards more line control integration and central data collection. This checkweigher/metal detector unit has been designed to meet these trends by allowing remote operation and data collection through a number of optional SCADA protocols.

Improving Process Efficiency

The advanced weighing controller within the combination unit allows customers to improve their process efficiencies and profitability. The extensive statistical graphic display information permits the line operator to instantly see the line performance and make any necessary adjustments to ensure the highest line efficiency. Automatic servo feedback controls to the filler will ensure that the maximum efficiency is maintained during the fill process. A number of feedback options are available to suit specific fill operations.

Aftermarket Services

Full ranges of aftermarket services are available to support the unit throughout its lifetime. These include commissioning at the time of installation. A full range of operating and service training modules are available either on site, or at one of the Thermo Fisher Scientific worldwide training facilities.

To ensure maximum operational efficiency we can offer on site maintenance contracts and a full spare parts service.



Available Options

- Integral printer with 42 characters per line for printing statistical data
- Local or remote 80 character per line printer for printing statistical data
- Zone lights mounted on side of unit to indicate the last product weight category
- Air jet or pusher for rejected product
- Failsafe reject mechanism
- Lockable reject bin and reject validation
- Digital or analog servo feedback control of fillers
- Product memory expansion to 400 products
- Menus available in English, Italian, Spanish, French, Dutch and German
- Communications port: RS 232C/RS 422/RS 485
- SCADA protocols:
 - Modbus
 - Ethernet (Modbus TCP/IP)
 - Device Net
 - Profibus
 - Allan Bradley RIO
- AuditCheck metal detection automatic validation unit
- Metal detection dual frequency for different packaging material

AC9 GP Combination

General Specifications

Operating temperature	-10°C to +50°C (+14°F to +122°F)
Relative humidity	20% to 50% non-condensing
Pack rate	up to 300 ppm dependent on product weight and length
Weight range	50 g to 500 g up to 90 m/min (1.61 oz to 1.1 lb up to 295 ft/min) 50 g to 2 kg up to 60 m/min (1.61 oz to 4.41 lb up to 197 ft/min)
Weigh conveyor length	300 mm (11.8 in) or 400 mm (15.7 in)
Accuracy	±100 mg (±1 sigma) dependent on pack weight and linear speed
Electrical supply	115/230 VAC, 50/60 Hz, 1 phase 15 amps 380/415 VAC, 50/60 Hz, 3 phase 5 amps
Air supply	5.5 bar (80 psi)
Line height	630 mm (24.8 in) to 1150 mm (45.3 in)
Metal detector aperture width	250 mm (9.85 in) wide
Metal detector aperture height options	50 mm (2.0 in), 75 mm (3.0 in), 100 mm (4.0 in), 125 mm (5.0 in), or 150 mm (6.0 in)
Maximum product size	200 mm (7.9 in) wide x 120 mm (4.7 in) high

AC9 GP Combination Physical Dimensions

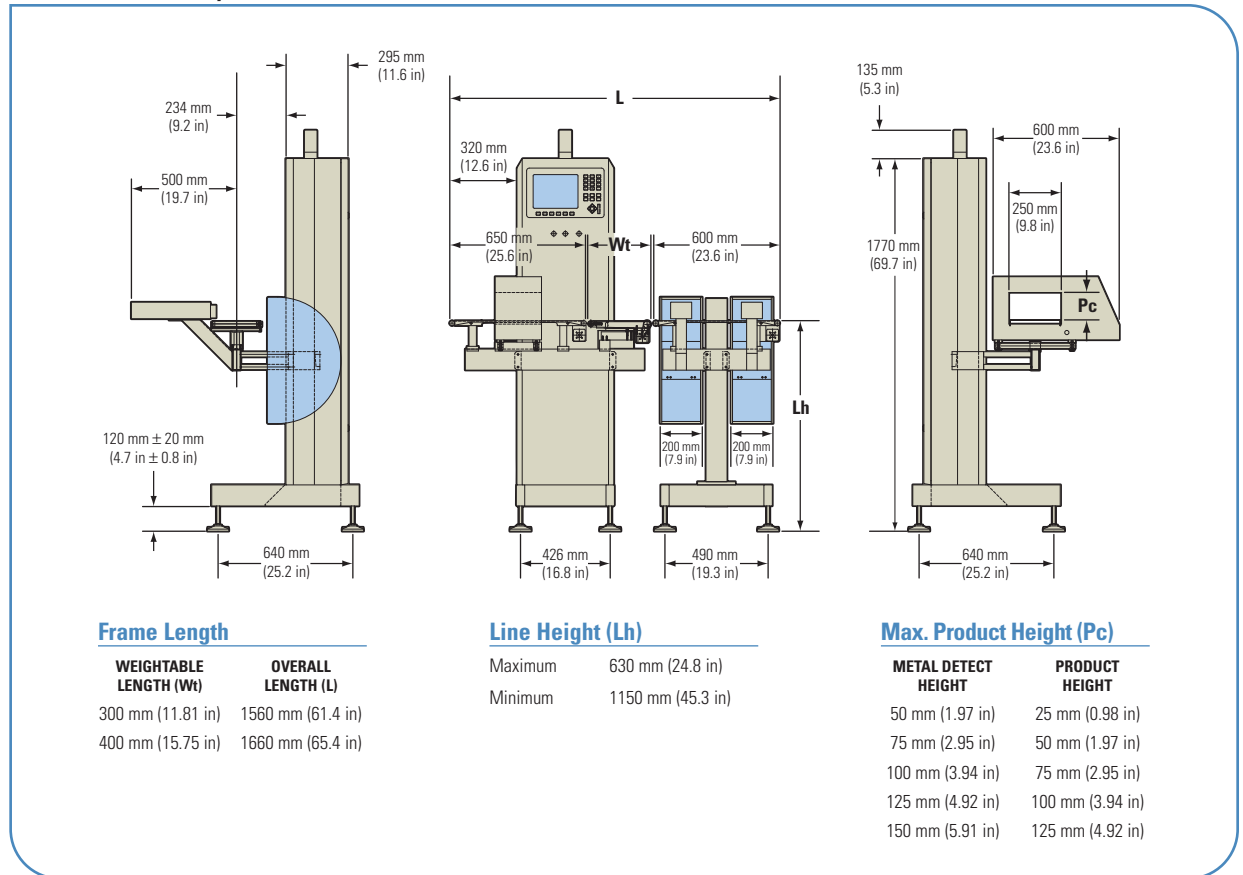

©2007 Thermo Fisher Scientific Inc. All rights reserved. All trademarks are the property of Thermo Fisher Scientific Inc. and its subsidiaries. Results may vary under different operating conditions. Specifications, terms and pricing are subject to change. Not all products are available in all countries. Please consult your local sales representatives for details. Literature Code PL0016.0907

Argentina +54 (0) 11 4334 3827 +54 (0) 11 4334 9159 fax	France +33 (0) 160 92 48 00 +33 (0) 160 92 49 00 fax	Mexico +52 (01) 55 5638 0237 +52 (01) 55 5639 2227 fax	United Kingdom +44 (0) 1788-820300 +44 (0) 1788-820301 fax
Australia +61 (0) 8 8150-5300 +61 (0) 8 8234-5882 fax	Germany +49 (0) 208-824930 +49 (0) 208-852310 fax	Netherlands +31 (0) 33-454-9000 +31 (0) 33-454-9009 fax	United States +1 (800) 227-8891 +1 (763) 783-2525 fax +1 (763) 783-2500 direct
Canada +1 (905) 888-8808 +1 (905) 888-8828 fax	India +91 (20) 6626 7000 +91 (20) 6626 7001 fax	Poland +48 (0) 22 651 75 30 +48 (0) 22 651 75 35 fax	
Chile +56 (0) 2-335-3388 +56 (0) 2-335-1590 fax	Italy +39 05 217886-1 +39 05 212729-14 fax	South Africa +27 (0) 11-609-3101 +27 (0) 11-609-3110 fax	
China +86 (0) 21 6865 4588 +86 (0) 21 6445 1101 fax	Malaysia +60 (0) 3 5122 8888 +60 (0) 3 5121 8899 fax	Spain +34 91-484-5954 +34 91-661-5572 fax	