

The Thermo Scientific Ramsey Model SWAX-7000 sweep type sampling machine offers an economical, simple means to procure a representative sample directly from a main stream of material. Direct increments are obtained from in-motion, horizontal or inclined conveyors. With over 40 years of experience in engineering and manufacturing, Thermo Scientific sampling systems are recognized worldwide as the finest available.

## Thermo Scientific Ramsey Model SWAX-7000 Primary Sweep Type Sampling Machine



The Thermo Scientific Ramsey Model SWAX-7000 sweep type sampling machine offers an economical, simple means to procure a representative sample directly from a main stream of material. Direct increments are obtained from in-motion, horizontal or inclined conveyors.

With over 700 units in service worldwide, the Ramsey™ Model SWAX-7000 can be used as a stand-alone sampling device to extract a cross belt cut to a sample container or as a primary (first stage cutter) in a multi-stage mechanical sampling system. The sweep type sampling machine has been subjected to rigorous, in-the-field testing, teaming with an extensive research and development

program. The Ramsey Model SWAX-7000 machine meets ASTM and ISO specifications. Parts and service on all Thermo Scientific sampling equipment are available on short notice from Minneapolis, Minnesota.

The Ramsey Model SWAX-7000 machine is ideally suited for sampling of coal, limestone, sand, crushed rock, gravel, ferrous and non-ferrous ores. Because of installation ease, the sweep type sampler is easily retrofitted to existing bulk material conveyor systems. Backed with over 40 years of experience in engineering and manufacturing, our sampling systems are recognized worldwide as the finest available.



### System Operation

The Ramsey Model SWAX-7000 sampler can be operated either manually or at pre-determined intervals depending upon the application and the customer's preference. When a cut of material is initiated the sampler rotates a full 360 degrees through the material on the moving belt. A complete cross sectional sample is taken. The sample is discharged through the outlet chute and either deposited into a sample collection container for size analysis or into a Self Contained Sampling Module (SCSU) for further processing.

Once the sample enters the SCSU the sample of material is deposited onto the primary belt feeder. The belt feeder meters the material into the crusher. The crusher reduces the product to required size without the loss of fines, while keeping moisture loss at a predictable and repeatable level. The sample is then split using a secondary sampling machine. These machines are designed to meet each sampling requirement.

Finally, the sample is collected in a dust/moisture tight container. The reject material from the sampling system is returned to the mainstream of material.

Several methods are available as dictated by operating requirements: gravity fall, screw conveyor, belt tube conveyor, or bucket elevator.

### Features

- Compact design is well-suited for low headroom installations.
- Ease of installation results in modest installation costs. Mounts directly to existing or new conveyors. No transfer points required.
- Rigid construction of tubular structural steel maintains positive alignment.
- Direct drive for positive stopping whether the belt is loaded or empty.
- Skirtboards on sampler prevent material spillage.
- Cost efficient. Small primary increment means smaller, less expensive equipment in the reduction stages of system.
- Non-contact proximity switches for start-stop control.
- Replaceable steel brushes and urethane wiper assure fines will be removed and included in representative sample.
- Samplers counterweighted to eliminate high eccentric loading on 36 in and larger belts.

### Self-Contained Sampling Unit (SCSU)

The SCSU provides a modular approach to sampling. It is available with all required equipment (except the primary sampler itself), pre-mounted and wired, and ready to hoist into place onto a concrete pad. The SCSU and the Ramsey Model SWAX-7000 can be placed at any convenient location along a suitable conveyor. It does not require an expanded transfer tower or expensive sampling tower, which minimizes installation costs. Optional equipment available includes roof with trusses, hinged side panels (insulated or non-insulated), ventilation fan, and heating.

### SCSU Features

- Utilizes primary sweep type sampling machine
- Completely pre-assembled structure for ease of mechanical installation
- Equipment completely pre-wired to PLC control panel and motor control center (optional)
- Full range of options including a totally enclosed module, heat and ventilation.



**Low Flow Compact Modular System**

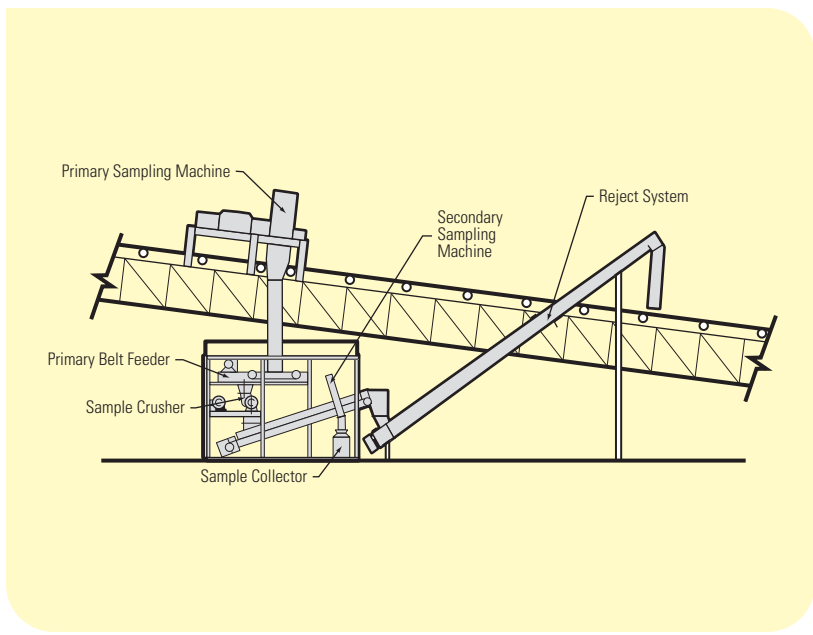

**Sampling System Components**

**Primary Sampling Machine**

Primary sweep type illustrated in conjunction with self-contained unit.

**Primary Belt Feeder**

Exclusively used to ensure uniform flow and to reduce dust and plugging problems.

**Sample Crusher**

The sample crusher is designed to reduce the product to required size.

**Secondary Sampling Machine**

The secondary sample reduction is handled by the Ramsey Model SWAX-7000 sweep type sampler.

**Sample Collector**

The collected material is contained in a dust/moisture-proof collector.

**Reject Systems**

The collected material is returned to the mainstream by a screw conveyor, bucket elevator, belt or tube conveyor, as illustrated.

**Compact Design**

Compact design is ideally suited for low headroom installations. Enclosed equipment completely pre-wired to PLC control panel and motor control center is available.

**Medium to High Flow Modular System**

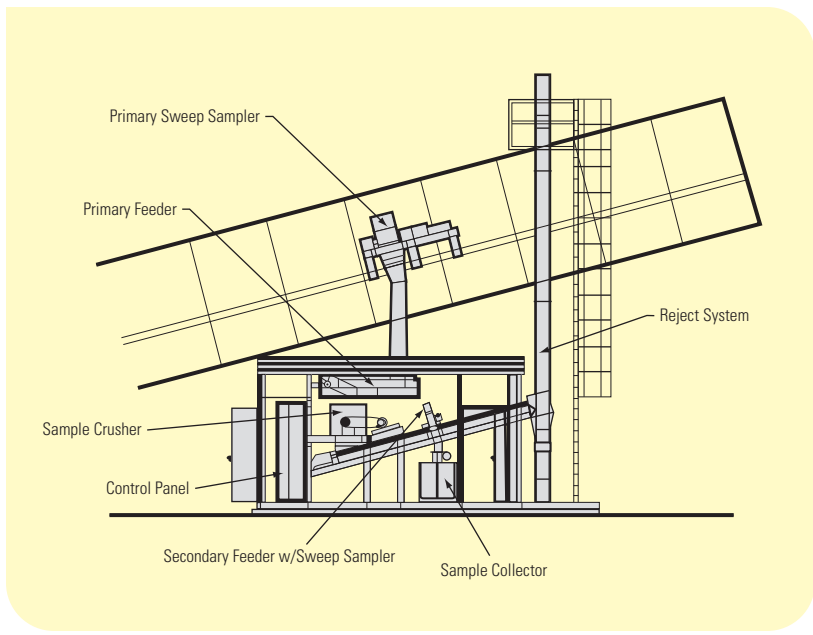

**Primary and Secondary Sampling System (without crushing)**

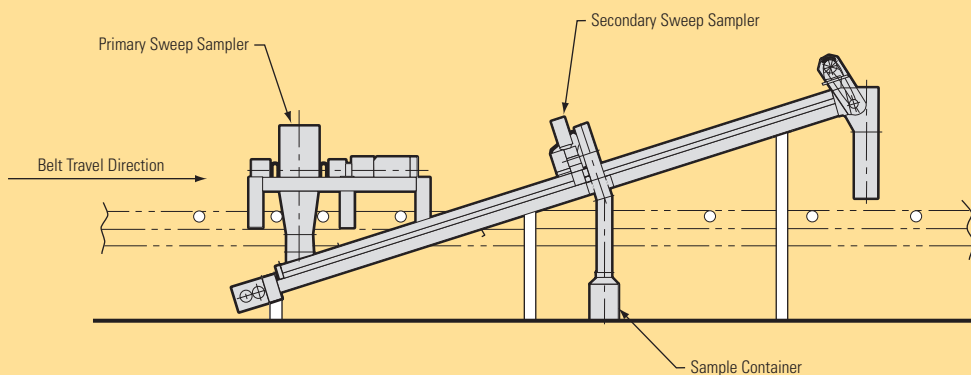

## Thermo Scientific Ramsey Model SWAX-7000

### Dimensions

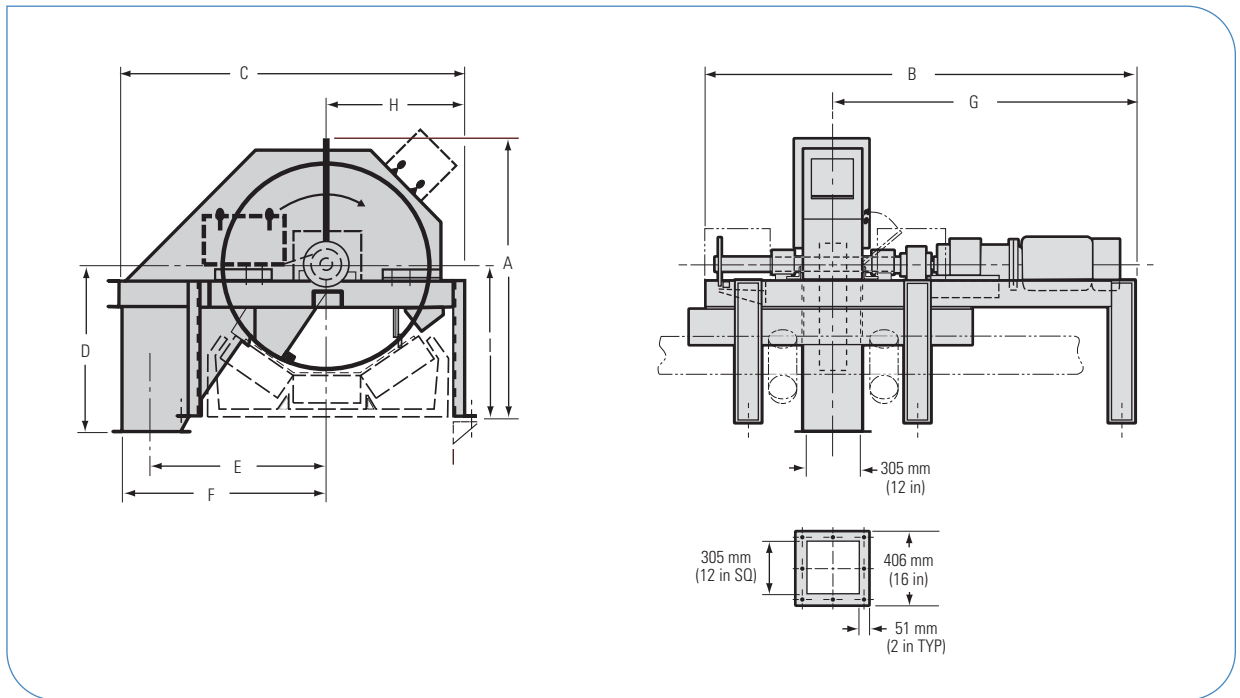

Belt Width	Dimensions									Net Weight
	A	B	C	D	E	F	G	H	I*	
<b>18 in</b>	838.20 mm (33.00 in)	2514.60 mm (99.00 in)	1155.70 mm (45.50 in)	558.80 mm (22.00 in)	533.40 mm (21.00 in)	609.60 mm (24.00 in)	1600.20 mm (63.00 in)	431.80 mm (17.00 in)	457.20 mm (18.00 in)	362.88 kg (800.00 lb)
<b>24 in</b>	1084.33 mm (42.69 in)	2514.60 mm (99.00 in)	1471.68 mm (57.94 in)	700.09 mm (27.56 in)	635.00 mm (25.00 in)	736.60 mm (29.00 in)	1600.20 mm (63.00 in)	558.80 mm (22.00 in)	341.38 mm (13.44 in)	453.60 kg (1000.00 lb)
<b>20 in</b>	1287.53 mm (50.69 in)	2660.65 mm (104.75 in)	1727.20 mm (68.00 in)	852.49 mm (33.56 in)	838.20 mm (33.00 in)	990.60 mm (39.00 in)	1638.30 mm (64.50 in)	609.60 mm (24.00 in)	671.51 mm (26.44 in)	771.11 kg (1700.00 lb)
<b>26 in</b>	1425.58 mm (56.13 in)	2927.35 mm (115.25 in)	1852.61 mm (72.94 in)	952.50 mm (37.50 in)	914.40 mm (36.00 in)	1068.80 mm (42.00 in)	1905.00 mm (75.00 in)	736.60 mm (29.00 in)	758.83 mm (29.88 in)	861.83 kg (1900.00 lb)
<b>42 in</b>	1597.03 mm (62.88 in)	3348.04 mm (131.81 in)	1879.60 mm (74.00 in)	1006.48 mm (39.63 in)	990.60 mm (39.00 in)	1143.00 mm (45.00 in)	2149.48 mm (84.63 in)	812.80 mm (32.00 in)	854.08 mm (33.63 in)	975.23 kg (2150.00 lb)
<b>48 in</b>	1817.69 mm (71.56 in)	3332.16 mm (131.19 in)	2133.60 mm (84.00 in)	968.38 mm (38.13 in)	1066.80 mm (42.00 in)	1219.20 mm (48.00 in)	2133.60 mm (84.00 in)	838.20 mm (33.00 in)	931.86 mm (36.69 in)	1043.27 kg (2300.00 lb)
<b>54 in</b>	2141.54 mm (84.31 in)	3806.83 mm (149.88 in)	2487.61 mm (97.94 in)	1201.74 mm (47.31 in)	1244.60 mm (49.00 in)	1397.00 mm (55.00 in)	2505.08 mm (98.63 in)	952.50 mm (37.50 in)	1014.41 mm (39.94 in)	1133.99 kg (2500.00 lb)
<b>60 in</b>	2101.85 mm (82.75 in)	3857.63 mm (151.88 in)	2647.95 mm (104.25 in)	1270.00 mm (50.00 in)	1295.40 mm (51.00 in)	1524.00 mm (60.00 in)	2555.88 mm (100.63 in)	1066.80 mm (42.00 in)	1095.38 mm (43.13 in)	2014.19 kg (4500.00 lb)
<b>72 in</b>	2433.64 mm (95.81 in)	3857.63 mm (151.88 in)	3209.93 mm (126.38 in)	1549.40 mm (61.00 in)	1625.60 mm (64.00 in)	1854.20 mm (73.00 in)	2555.88 mm (100.63 in)	1038.10 mm (41.00 in)	1255.71 mm (49.44 in)	2494.78 kg (5500.00 lb)
<b>84 in</b>	2911.60 mm (114.63 in)	3895.85 mm (153.38 in)	3416.30 mm (134.50 in)	1873.25 mm (73.75 in)	1727.20 mm (68.00 in)	1955.80 mm (77.00 in)	2600.20 mm (102.37 in)	1409.70 mm (55.50 in)	1522.48 mm (59.94 in)	2948.38 kg (6500.00 lb)
<b>96 in</b>	3584.45 mm (141.12 in)	3895.85 mm (153.38 in)	3721.10 mm (146.50 in)	2035.05 mm (80.12 in)	1879.60 mm (74.00 in)	2108.20 mm (83.00 in)	2600.20 mm (102.37 in)	1562.10 mm (61.50 in)	1682.75 mm (66.25 in)	3401.98 kg (7500.00 lb)

\*Dimensions dependent on idler height.

Note: 1. Dimensions are approximate. They will be confirmed at the time of order.  
2. For belt sizes smaller or larger than shown, please consult factory.

© 2008 Thermo Fisher Scientific Inc. All rights reserved. All trademarks are the property of Thermo Fisher Scientific Inc. and its subsidiaries. Results may vary under different operating conditions. Specifications, terms and pricing are subject to change. Not all products are available in all countries. Please consult your local sales representative for details. Literature Code PI.8051.1108

Australia +61 (0) 8 8208 8200 +61 (0) 8 8234 3772 fax	China +86 (0) 21 6865 4588 +86 (0) 21 6445 7830 fax	Netherlands +31 (0) 76-579-5555 +31 (0) 76-571-4958 fax	United States +1 (800) 445-3503 +1 (763) 783-2525 fax +1 (763) 783-2500 direct
Canada +1 (905) 888-8808 +1 (905) 888-8828 fax	Germany +49 (0) 208-824930 +49 (0) 208-852310 fax	South Africa +27 (0) 11-609-3101 +27 (0) 11-609-3110 fax	
Chile +56 (0) 2 378 8050 +56 (0) 2 370 1082 fax	India +91 (20) 6626 7000 +91 (20) 6626 7001 fax	Spain +34 (0) 91-484-5965 +34 (0) 91-484-3597 fax	
	Italy +39 02-959514-1 +39 02-953200-15 fax	United Kingdom +44 (0) 1788-820300 +44 (0) 1788-820301 fax	<a href="http://www.thermo.com/bulk-handling">www.thermo.com/bulk-handling</a>