

The Thermo Scientific Ramsey Model 90.151 offers accurate weighfeeding of light materials at low feed rates. Its unique design and construction features provide a consistent flow of materials, offer increased sensitivity for more accurate weighing of the lightest materials, and permit quick and easy cleaning and maintenance. These features work together to augment the performance of your process and improve your bottom line.

## Thermo Scientific Ramsey Model 90.151 Conveyor Weighing of Bulk Materials

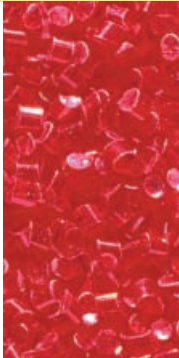

Thermo Scientific Ramsey Model 90.151 low capacity weighbelt feeder shown without side cover



Cantilevered frame and quick release take-up for easy belt removal

Precise feeding of process materials is often critical to maintaining product quality. A feeder that weighs accurately and reliably can reduce material waste, help maintain blend consistency and increase profits.

We have well over 30 years of experience designing and manufacturing weighbelt feeders. Every feeder is designed to meet the specific needs of the application. We work closely with our customers to ensure that each system meets their expectations for performance and dependability.

The Thermo Scientific Ramsey Model 90.151 low capacity weighbelt feeder is designed for weighfeeding applications with low feed rates and light belt loading requirements. It accommodates flow rates as low as 54 kg (120 lb) per hour up to 22,680 kg (50,000 lb) per hour, and belt loadings of 3 kg/m (2 lb/ft) to 30 kg/m (20 lb/ft).



**Ramsey Model 90.151  
Low Capacity Weighbelt Feeder**

### **Theory of Operation**

Material is fed onto the feeder through an inlet feed section equipped with a manually adjustable vertical slide gate to control material height. The scale carriage/weighbridge assembly measures the gravitational force of the material and converts this force measurement into an electrical output signal proportional to belt loading.

A digital speed sensor continuously monitors the belt speed. The microprocessor-based electronics integrate the two signals to produce and display a true rate and a total weight fed. The electronics also provide an output signal for control and monitoring purposes.

For more information, refer to the separate product specification sheet on the Thermo Scientific Ramsey Micro-Tech 2000 or 3000 series of electronic integrators.

### **Features and Benefits**

The Ramsey™ Model 90.151 low capacity weighbelt feeder, with its innovative design and unique features, was developed to meet the high standards and greater accuracy demands of today's food, chemical and process industries.

- *Unique Head Pulley Configuration:* The chisel-shaped pulley configuration on the discharge end of the belt provides an even, consistent flow of difficult process materials off of the belt.
- *Tail Drive Arrangement:* This reduces carry-side belt tensions to provide greater sensitivity for more accurate weighing of the lightest materials.
- *Cantilever Design:* This feature permits quick and easy belt removal for cleaning and maintenance.
- *Dual Load Cell Scale:* Dual load cells enable a higher degree of response to material weight variations.
- *Stainless Steel Construction:* Stainless steel provides improved corrosion resistance and washdown capabilities.

**Ramsey Model 90.151 Low Capacity Weighbelt Feeder — Schematic Diagram**

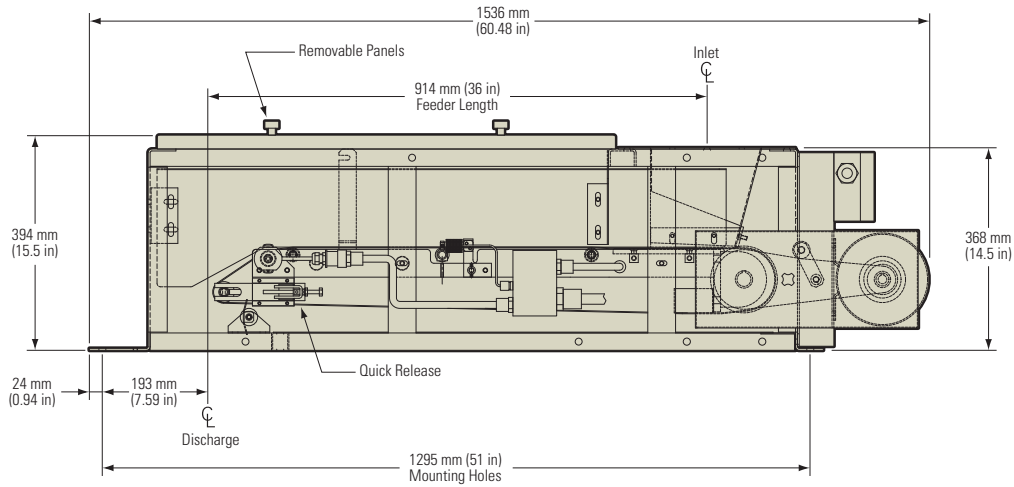

**SIDE VIEW**

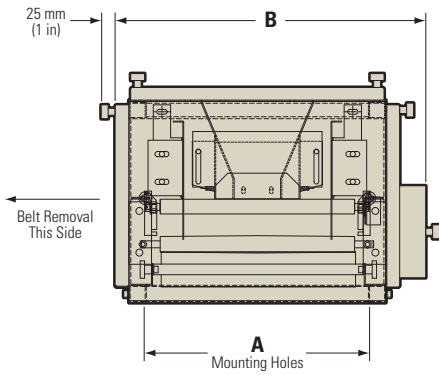

**END VIEW**

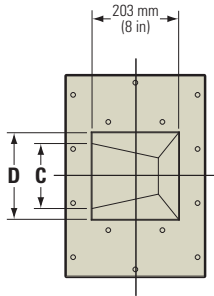

**INLET FLANGE DETAIL**

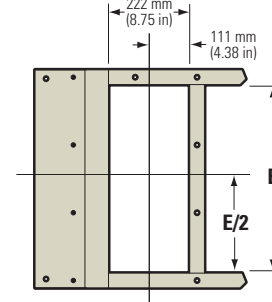

**DISCHARGE FLANGE DETAIL**

**Ramsey Model 90.151 Low Capacity Weighbelt Feeder — Variable Dimensions**

BELT WIDTH	LENGTH (mm)				
	A	B	C	D	E
305 mm	432	568	152	203	406
457 mm	584	721	305	356	559
610 mm	737	873	457	508	711

BELT WIDTH	LENGTH (in)				
	A	B	C	D	E
12 in	17	22.38	6	8	16
18 in	23	28.38	12	14	22
24 in	29	34.38	18	20	28

## Thermo Scientific Ramsey Model 90.151

### General Specifications

Accuracy	±0.25% to 1% of set rate at 2 sigma, based on approved applications and test requirements
Belt Width	305 mm (12 in), 457 mm (18 in), 610 mm (24 in)
Feeder Length	914 mm (36 in) to 1,829 mm (72 in) centerline of inlet to centerline of discharge
Feed Rate	54.4 kg/hr to 22,680 kg/hr at 801 kg/m <sup>3</sup> (120 lb/hr to 50,000 lb/hr at 50 lb/ft <sup>3</sup> ) material
Belt Load	3 kg/m to 29.8 kg/m (2 lb/ft to 20 lb/ft)
Weigh Span	273 mm (10.75 in) typical
Belt	Endless polyester/monofilament carcass with FDA/USDA covers suitable for the application; Other belts available depending on application
Idlers	25.4 mm (1 in) diameter stainless steel with sealed bearings
Head Pulley	38.1 mm (1.5 in) diameter stainless steel with special chisel-shaped configuration
Speed Reducer	Motovario or equal shaft mount
Scale Weighbridge	Dual load cell, single-idler, pivotless full-floating weighbridge
Conveyor	Cantilevered frame and quick release take-up for easy belt removal; Stainless steel construction; Customer may specify belt removal on either the left or right side
Load Cell	Dual, low capacity bending beam transducers
Load Cell Excitation	10 VAC/DC recommended, 20 VAC/DC maximum
Nonlinearity	0.02% rated output
Repeatability	0.01% rated output
Hysteresis	0.02% rated output
Temperature Sensitivity	Zero: 0.0014% rated output/°C (0.0008% rated output/°F) Span: 0.0014% load/°C (0.0008% load/°F)

### Digital Speed Sensor

Type	Digital, brushless
Mounting	Direct to shaft
Housing	Weather-tight

### Options

- Top covers
- Side covers
- Bottom covers
- Variable speed drives
- Flow/no-flow switches
- Plugged chute switches
- Class 1 and 2 rated units
- High temperature belts
- Shut-off/maintenance gates

© 2008 Thermo Fisher Scientific Inc. All rights reserved. All trademarks are the property of Thermo Fisher Scientific Inc. and its subsidiaries. Results may vary under different operating conditions. Specifications, terms and pricing are subject to change. Not all products are available in all countries. Please consult your local sales representative for details. Literature Code PI.8022.1108

	China	Netherlands	United States
	+86 (0) 21 6865 4588	+31 (0) 76-579-5555	+1 (800) 445-3503
	+86 (0) 21 6445 7830 fax	+31 (0) 76-571-4958 fax	+1 (763) 783-2525 fax
Australia	Germany	South Africa	+1 (763) 783-2500 direct
+61 (0) 8 8208 8200	+49 (0) 208-824930	+27 (0) 11-609-3101	
+61 (0) 8 8234 3772 fax	+49 (0) 208-852310 fax	+27 (0) 11-609-3110 fax	
Canada	India	Spain	
+1 (905) 888-8808	+91 (20) 6626 7000	+34 (0) 91-484-5965	
+1 (905) 888-8828 fax	+91 (20) 6626 7001 fax	+34 (0) 91-484-3597 fax	
Chile	Italy	United Kingdom	<a href="http://www.thermo.com/bulk-handling">www.thermo.com/bulk-handling</a>
+56 (0) 2 378 8050	+39 02-959514-1	+44 (0) 1788-820300	
+56 (0) 2 370 1082 fax	+39 02-953200-15 fax	+44 (0) 1788-820301 fax	