

The HAAKE PCR-620 is a twin-pump bypass rheometer that provides on-line rheological measurements of Melt Index and Viscosity in polymer processing. With over 200 successful installations of the PCR-620 and its predecessors around the world, Thermo Electron Corporation is a leader in advanced process control technology for the polymer processing industry.

HAAKE PCR-620 Process Control Rheometer

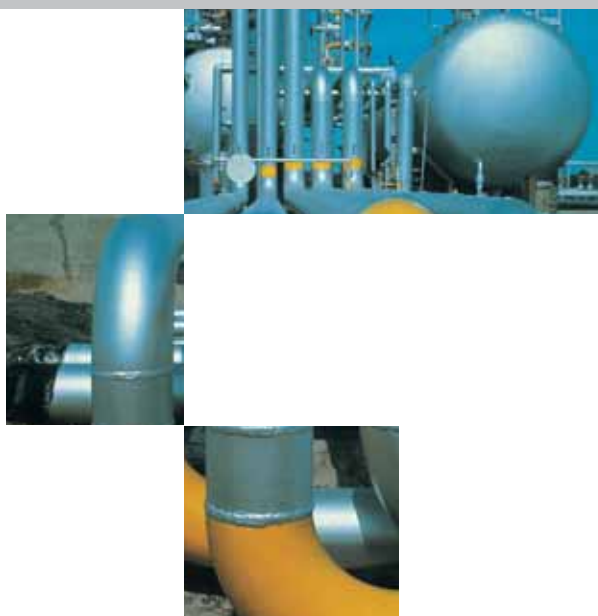

Applications:

- On-Line Melt Index measurement
- On-Line viscosity measurement

Materials:

- Polypropylene (PP)
- Polyethylene (LDPE/HDPE/LLDPE)
- Polyester (PET)
- Ethylene Vinyl Acetate (EVA)
- Polymethyl-methacrylate (PMMA)
- Polystyrene (PS)
- Polyamide / Nylon (PA)
- Polycarbonate (PC)

Applications

The HAAKE PCR-620 (Process Control Rheometer) measures the Melt Index at standard ASTM loads or at higher loads (with back-calculation to standard load) in order to reduce lag time. The patented slit die pressure control feature allows the PCR-620 to operate at pressures above the process pressure, thereby ensuring operation in the linear region of the transducers and preventing out-gassing. This also allows the PCR-620 to cover a wide Melt Index range and follow transitions with a single die eliminating costly and troublesome die changes common to other systems.

The PCR-620 can operate in a variety of modes: Melt Index mode, Transition Melt Index mode, Purge mode, Viscosity mode (stress or rate control) and combinations of those.

The PCR-620 can also report a synthesized Mooney or Intrinsic Viscosity (IV) value mathematical calculation from measured shear viscosity data. For ease of operation, recipes consisting of operating parameters and control values can be stored for various product grades. The PCR-620 logs all data and events in a database for trend analysis, SPC reporting and data storage.

The PCR-620 is a "return to stream" design and is available with a valve block for process isolation and an optical block to allow on-line spectroscopic analysis (offered as options, additional equipment required). All melt pumps and slit dies are easily exchangeable to adapt the PCR-620 to specific processes.

HAAKE Rheometer

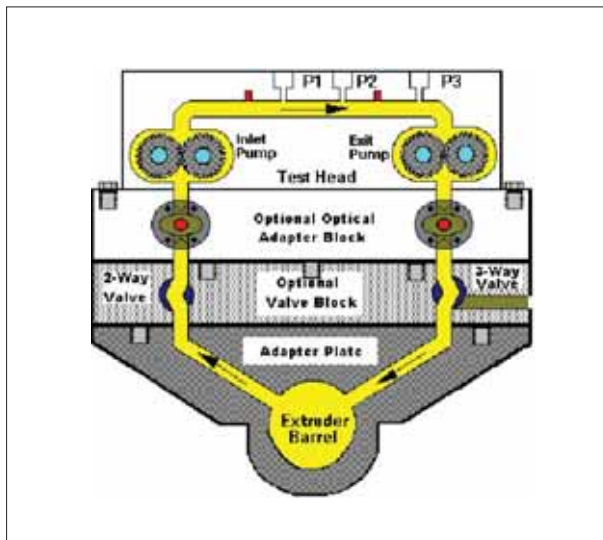

Control Features

The PCR-620 electronics, based on the SLC-500 PLC from Rockwell International (Allen-Bradley), provides superior support and integration using industry standard components and technologies. New software features provide capabilities never before available.

The NEW Process Supervisor for Windows software offers unmatched ease-of-use and an operator friendly design.

The software, based on RSView32, is designed for integration into plant DCS systems. It offers data communication with a variety of protocols like, Data Highway plus, ModBus and the latest innovation in process control, OPC (OLE for Process Control). Standard analog signals (4-20 mA or 24 VDC) are available also.

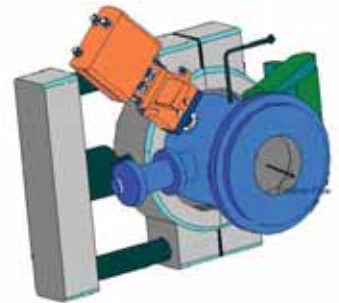

Technical Specifications HAAKE PCR-620

Stress	5 kPa to 250 kPa*
ASTM D-1238 loads	0.5 Kg to 25 Kg
Shear Rate	0.03 to 4,000 1/sec*
Viscosity	1 to 200,000 Pa.s 10 to 2,000,000 poise
Melt Flow Index	0.02 to 3,000*
Temperature	50°C to 350°C (400°C option)
Pumps	Rheometer: 0.584 cc/rev to 2.92 cc/rev Max. Speed: 60 rpm
Pressure Transducers	100 bar to 350 bar (1500 psi to 5000 psi)
Slit Dies	Height 0.03 cm to 0.2 cm Width 2.25 cm to 1.2 cm Length 4 cm to 8 cm
EX proof on request	
Power	220 VAC, 30A, single phase, 50/60 Hz
Weight	Rheometer: 104 kg (230 lbs) Electronics: 43 kg (95 lbs)

* geometry dependent

Installation & Maintenance

Installation expertise exists for adaptation to extruders from all the major manufacturers. The PCR-620 is typically installed on finishing and compounding extruders upstream to a pelletizer or mounted as a side stream with a piping adapter. It can be retrofitted to many existing process systems. The PCR-620 uses permanently lubricated, sealed-for-life gearboxes, allowing it to be mounted in any orientation. The PCR-620 is interchangeable with existing PCR and MFM installations as an upgrade option. The PCR-620 is backed-up by a worldwide, direct support system for service and training of plant personnel. Thermo also provides services to assist with the integration of the PCR-620 in plant DCS systems.

The PCR-620 design concept provides superior ease of maintenance features and easy access to all critical components. The PCR-620 can be removed from the process by closing its isolation valves and removing only 2 bolts. The vast majority of maintainable components are standard stock items from major vendors of polymer processing hardware.

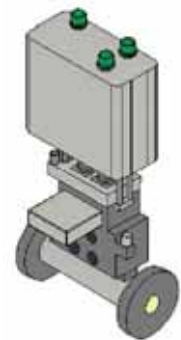
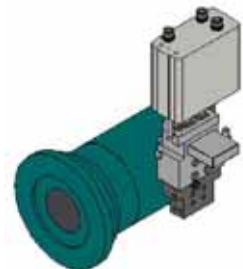

Thermo Electron Corporation

Material Characterization Business

International/Germany
Thermo Electron (Karlsruhe) GmbH
Dieselstr. 4
76227 Karlsruhe
Tel. +49 (0) 721 4 09 44 44
info.mc.de@thermo.com

Benelux
Thermo Electron B.V.
Takkebijsters 1
4817 BL Breda
Tel. +31 (0) 76 5 87 98 88
info.mc.nl@thermo.com

China
Thermo Electron
23/F Peregrine Plaza
1325 Huai Hai Rd, Shanghai 200031
Tel. +86 (21) 54 65 75 88
info.china@thermo.com

France
Thermo Electron S.A.
16 Avenue du Québec - Silic 765
91963 Courtaboeuf Cedex
Tel. +33 (0) 1 60 92 48 00
info.mc.fr@thermo.com

United Kingdom
Thermo Electron
Emerald Way, Stone
Staffordshire ST15 0SR
Tel. +44 (0) 1785 81 36 48
info.mc.uk@thermo.com

USA
Thermo Electron
25 Nimble Hill Rd.
Newington, NH 03801
Tel. 603 436 9444
info.mc.us@thermo.com