

# Thermo Scientific Orion 2100 Series Analyzer Surface Mounting Kit

## Mounting Specifications

All dimensions are in inches, with a tolerance of  $\pm 0.01$  inch.

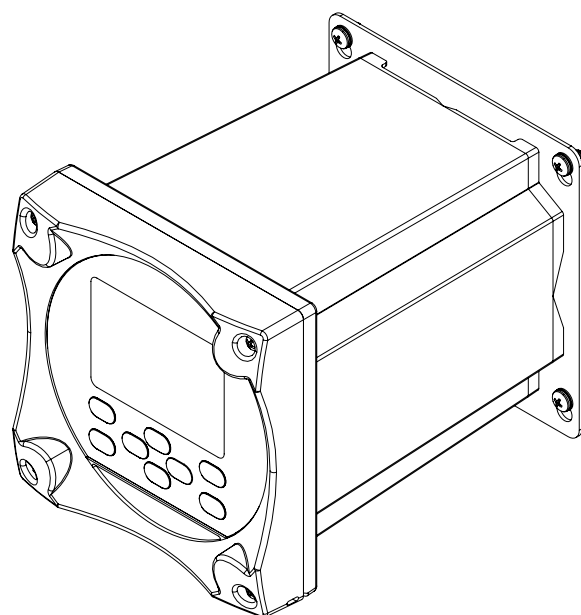
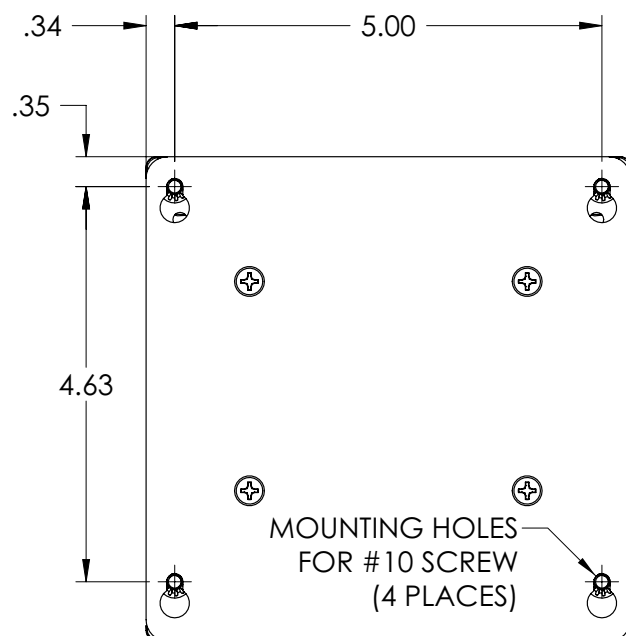
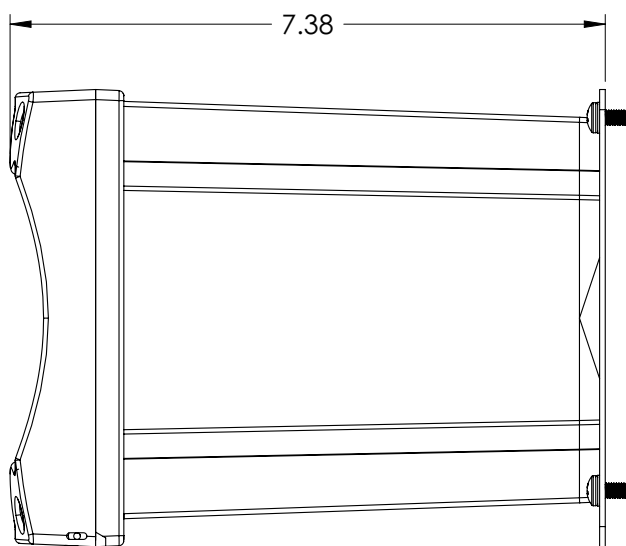
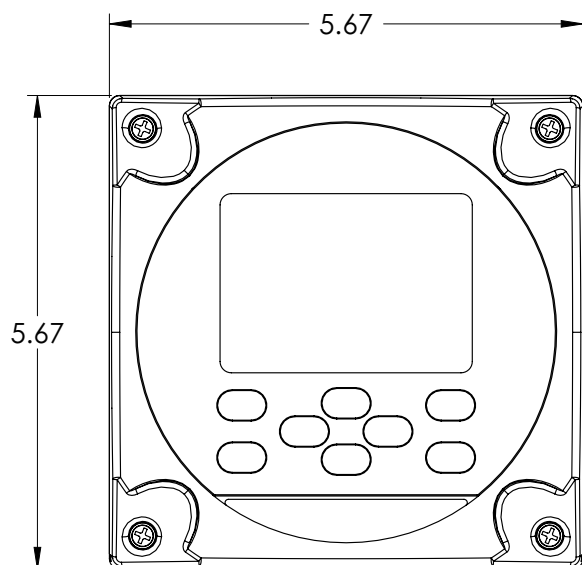

## Mounting Instructions

1. Drill four holes for the #10 screws into the desired mounting surface. Drill the holes in the 5.00" by 4.63" rectangular pattern shown on the previous page.
2. Assemble the mounting plate (**item 2**) with the monitor housing (**item 1**) and secure the assembly with the four #8 countersunk screws (**item 3**).
3. Position the mounting plate on the desired mounting surface and secure the assembly with four #10 screws (**item 4 – not included**) in the holes drilled into the mounting surface. Note that the four #10 screws are not included in the kit and must be supplied by the operator.

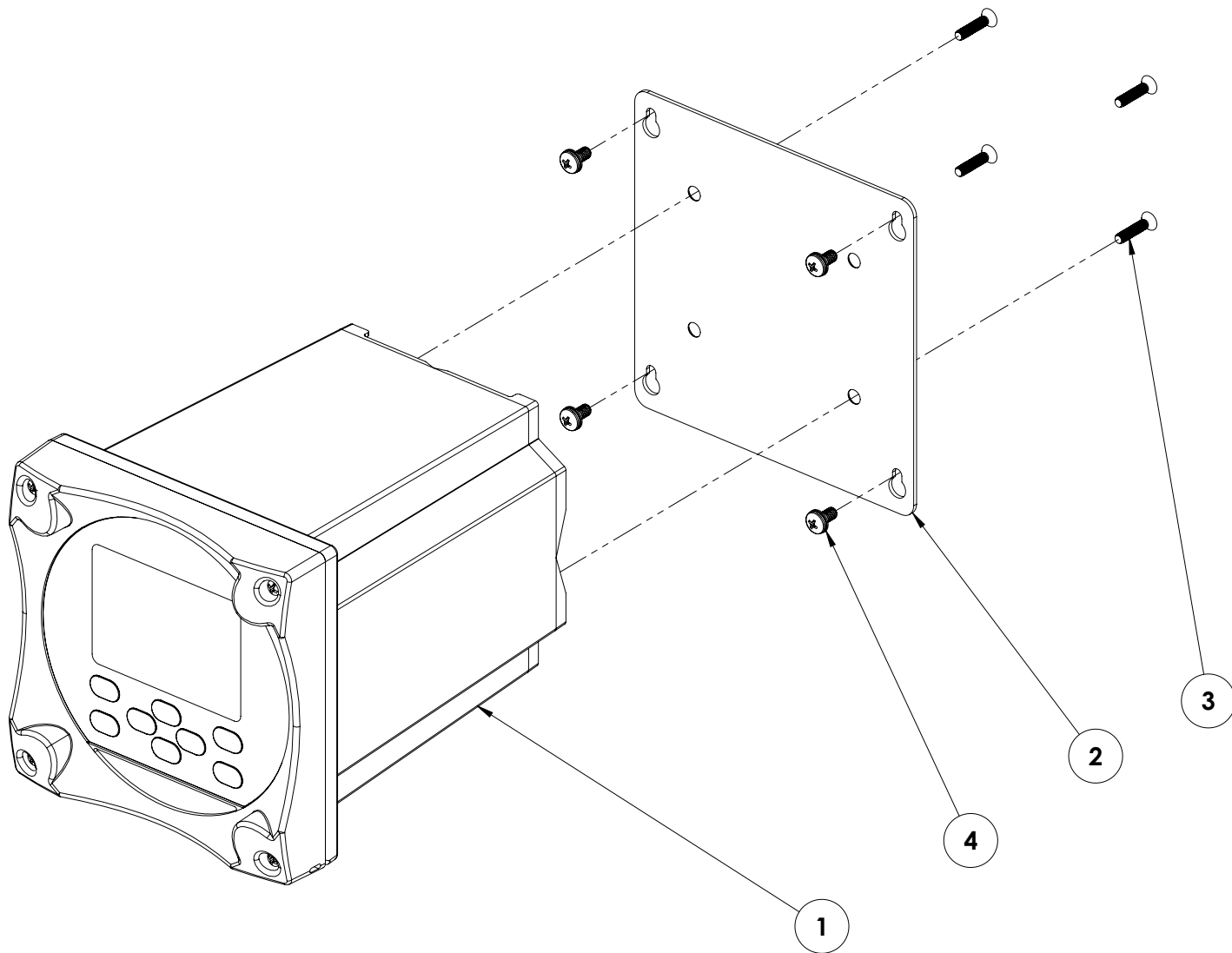

©2009 Thermo Fisher Scientific Inc. All rights reserved. All trademarks are the property of Thermo Fisher Scientific Inc. and its subsidiaries.



### Process Water Instruments

**North America**  
166 Cummings Center  
Beverly, MA 01915 USA  
Toll Free: 1-800-225-1480  
Tel: 1-978-232-6000  
Dom. Fax: 1-978-232-6015  
Int'l Fax: 978-232-6031

**Europe**  
P.O. Box 254, 3860 AG Nijkerk  
Wallerstraat 125K, 3862 CN  
Nijkerk, Netherlands  
Tel: (31) 033-2463887  
Fax: (31) 033-2460832

**Asia Pacific**  
Blk 55, Ayer Rajah Crescent  
#04-16/24, Singapore 139949  
Tel: 65-6778-6876  
Fax: 65-6773-0836

[www.thermo.com/processwater](http://www.thermo.com/processwater)